

# Panasonic

## Ventilation and Indoor Air Quality Solutions



# Panasonic



## Award Winning Commitment to Innovation

Our longstanding record of industry recognition continues. The Environmental Protection Agency (EPA) recognized Panasonic with the ENERGY STAR® Partner of the Year Sustained Excellence Award, which demonstrates exemplary commitment to leadership in energy efficiency and the ENERGY STAR® program.

## Table of Contents

The Power of Panasonic	4-5
Powerful Ventilation and IAQ Solutions	6-7
<b>Ventilation Fans</b>	<b>8</b>
WhisperGreen Select	10-19
WhisperSense DC	20
WhisperCeiling DC	21
WhisperCeiling	22
WhisperRecessed LED	23
WhisperFit DC	24-25
WhisperValue DC	26-29
WhisperWarm DC	30
EcoVent	31
WhisperFresh Select	32-33
<b>Energy Recovery Ventilators (ERVs)</b>	<b>34</b>
BalancedHome	36-39
Intelli-Balance 100	40-41
Intelli-Balance 200	42
WhisperComfort 60	43
SelectCycler	44-45
Dryer Exhaust Duct Ventilators	46
In-line Fans	50
<b>Smart Controls</b>	<b>56</b>
Swidget	58-59
WhisperControl	60-61
Purification	62
WhisperAir Repair	64-65
<b>Accessories</b>	<b>66</b>
WhisperVent WallCapt	68
EZSoffitVent	68
Ceiling Radiation Damper	69
Designer Grilles	69
EcoSwitch	70
Recessed Inlet	70
Smart Exhaust	71
Performance Curves	72-77
Dimensional Drawings	78-82
FAQ	83-85
Ventilation Controls	86
Sizing Information and Instructions	87
Installation	88-89

# The Power of Panasonic

## Rely on a higher power

Panasonic ventilations fans help reduce issues with poor ventilation, remove unhealthy air, meet code requirements, reduce callbacks and enhance customer satisfaction, ultimately supporting healthier homes.



Ensure code compliance



Reduce callbacks



Simplify design & installation



Guarantee customer satisfaction

## Why power rating matters

Effective ventilation requires strong airflow. Panasonic fans deliver unmatched air-moving performance, verified in real-world tests, exceeding standard static pressure benchmarks. ECM motors ensure powerful airflow event at typical installation pressures.

### Did you know?

Tests conducted by Lawrence Berkeley National Laboratory revealed that almost half of all installed ventilation fans do not meet ASHRAE 62.2, despite their advertised CFM.

When you install a Panasonic ventilation fan you get the promised **True Flow rating** as listed on the box.

## Certified & Code Compliant

Panasonic ventilation fans are certified by the Home Ventilating Institute (HVI) and ENERGY STAR® certified, compliant ASHRAE 62.2, ENERGY STAR® for Homes 3.2, Indoor airPlus, CALGreen, NAHB Green Building Standard, EarthCraft and other green building programs.

## Commitment to Indoor Air Quality & Healthy Homes

Panasonic is a member of the Indoor Air Quality Association (IAQA), we adhere to industry standards, ensuring high indoor air quality and healthy homes.



Learn more at [iaq.na.panasonic.com](http://iaq.na.panasonic.com)

## Powerfully quiet

Panasonic ventilation fans provide high performance and whisper-quiet operation, efficiently removing air pollutants.

## Long Life

Motors are engineered for continuous use; up to 30,000 hours of AC and 60,000 hours of DC (ECM) motors, featuring rust-resistant paint and durable housing.

## Easy Installation

Features like duct adapters, adjustable mounting brackets (up to 24" o.c.) and easy-to-remove fan/motor units simplify installation. Flex-Z Fast (R) single-hinged brackets ensure flexible, hassle-free setup.

## Energy Savings

When it comes to energy efficiency, our low wattage requirements are among the lowest in the industry. Our fans have also been engineered to comply with ENERGY STAR® 4.1 delivering cost-effective performance.

## Safety

WhisperGreen® Select models are protected by UL Class 2 Power Unit while all other models are equipped with thermal fuse protection. With the exception of the ERV's and fan/heaters, all models are UL listed for tub/shower enclosure when GFCI protected.

## Airflow

Integrated plastic or metal dampers in all ceiling-mounted applications help prevent backdraft. The built-in metal flanges block air leads through drywall to increase performance.

## Lighting

All of our lighted models are equipped with JA8 compliant LED lights for CA Title 24. Offering 50,000 hours of life and integrated night lights.

## Green Manufacturing

All "fan only" models are RoHS compliant. Restriction of Hazardous Substances Directive (RoHS) restricts the use of the following six substances in the manufacturing process: Lead, Mercury, Cadmium, Hexavalent Chromium [CR(VI)], Polybrominated Biphenyls (PBB), and Polybrominated Diphenyl Ether (PBDE).

## Warranty

ECM motors have a 6-year warranty, LEDs a 5-year warranty, and AC motors a 3-year warranty.

Note: All our ventilation fans are UL listed for tub/shower enclosure when GFCI protected except for WhisperFresh Select, Intelli-Balance 100/200, WhisperComfort 60 and WhisperWarm DC fans.

# VENTILATION

**WhisperGreen Select**  
VENTILATION FAN  
One Fan - Multiple IAQ Solutions



**WhisperCeiling DC**  
VENTILATION FAN  
Precision Spot Ventilation Solution

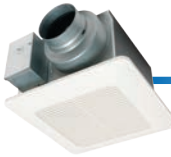

**WhisperSense DC**  
VENTILATION FAN  
Precision Spot Ventilation Solution with built-in Dual Sensor Technology



**WhisperValue DC**  
VENTILATION FAN  
Ideal Multi-Family Solution



**WhisperFit DC**  
VENTILATION FAN  
Ideal Retrofit Solution

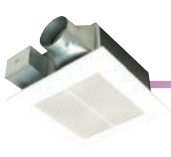

**WhisperWarm DC**  
VENTILATION FAN  
Quiet, Fan/Heater Solution



**WhisperFresh Select**  
VENTILATION FAN  
Whole-House Supply Ventilation



**ecovent**  
Cost Effective, Spot Ventilation Solution



**WhisperRecessed LED**  
VENTILATION FAN  
Ideal Design Solution



# ERV / BALANCED STRATEGY



**BalancedHome**  
Balanced Ventilation For Any Solution



**Intelli-Balance 100**  
Balanced Air Solution For Any Climate Zone - 50 to 100 CFM



**Intelli-Balance 200**  
Balanced Air Solution For Any Climate Zone - 60 to 200 CFM

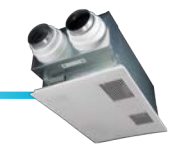

**WhisperComfort 60**  
Economical and Easy to Install Balanced Air Solution



**SelectCycler**  
WHOLE HOUSE VENTILATION SYSTEM  
Whole House Ventilation Solution

# SMART CONTROLS

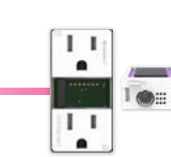

**SWDGET**  
POWER TO LIVE SMART  
Modular Smart Devices



**WhisperControl**  
Condensation Sensor Solution

# PURIFICATION



**WhisperAir Repair**  
PURIFIED BY nanoEX  
Ceiling Mount Spot Purification Device

# ATMOSPHERE



**ATMOSPHERE**  
Dryer Exhaust Duct Power Ventilators & In-line Fans





Underperforming ventilation fans can expose occupants to poor indoor air quality and put your business at risk. Issues like non-compliance, warranty claims, callbacks, legal liabilities, and damage to reputations can arise.

Panasonic's powerful ventilation fans effectively eliminate unhealthy air, ensuring homes meet code requirements consistently.

Eliminate risks with Panasonic high performing ventilation fans.

**FV-0511VK3** 50-80-110 CFM 4" or 6" Duct  
**FV-0511VKS3** 30 to 110 CFM 4" or 6" Duct  
**FV-1115VK3** 110-130-150 CFM 6" Duct  
**FV-0511VKS3S** 30 to 110 CFM 4" or 6" Duct



**KEY FEATURES**

**Increased Energy Efficiency**

Comply with the more stringent ENERGY STAR® criteria of 11.4 CFM/watt with the improved DC motor and overall design enhancements.

**Designer Grille Options**

Sharper, cleaner lines on the traditional grille and two new architectural grille designs for a more elegant appeal.

**Expanded True Flow Performance**

HVI-certified performance at 0.5" w.g., exceeds industry standards and helps you build beyond expectations.

**WiFi Module**

Responds automatically to poor air conditions. Communicates with other ventilation devices, including supply fans and energy recovery ventilators, to manage indoor air quality more efficiently.



**Wi-Fi Module**  
(WP100PBA)



**Smart Action® Motion Sensor + Condensation Sensor** (FV-CMVK3)



**Multi-Speed with Time Delay\*\*** (FV-VS15VK1)  
(Included with FV-0511VKS3)



**SmartAction® Motion Sensor\*\*** (FV-MSVK1)



**Condensation Sensor\*\*:** RH sensitivity adjustment (30%-80%) (FV-CSVK1)



**Flex-Z Fast®:** Single-hinged Flex-Z Fast® bracket provides flexible, fast and easy installation

**Plug 'N Play Receptacles & Pick-A-Flow® Switch**



**FV-0511VKL3** 50-80-110 CFM 4" or 6" Duct  
**FV-0511VKSL3** 30 to 110 CFM 4" or 6" Duct  
**FV-1115VKL3** 110-130-150 CFM 6" Duct  
**FV-0511VKSL3K** 30 to 110 CFM 4" or 6" Duct



**KEY FEATURES**

**Increased Energy Efficiency**

Comply with ENERGY STAR® criteria of 11.4 CFM/watt with the improved DC motor and overall design enhancements.

**Designer Grille Options**

Sharper, cleaner lines on the traditional grille and two new architectural grille designs for a more elegant appeal.

**LED Lighting**

Five color changing temperature light module for the architectural model provides the option to match any desired lighting levels.  
 FV-0511VKSL3K ( 3000K, 3500K, 4000K, 5000K, 6000K

**Expanded True Flow Performance**

HVI-certified performance at 0.5" w.g., exceeds industry standards and helps build beyond expectations.

**WiFi Module**

Responds automatically to poor air conditions. Communicates with other ventilation devices, including supply fans and energy recovery ventilators, to manage indoor air quality more efficiently.



**Wi-Fi Module**  
(WP100PBA)

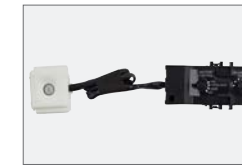

**Smart Action® Motion Sensor + Condensation Sensor** (FV-CMVK3)



**Multi-Speed with Time Delay\*\*** (FV-VS15VK1)  
(Included with FV-0511VKS3)



**SmartAction® Motion Sensor\*\*** (FV-MSVK1)



**Condensation Sensor\*\*:** RH sensitivity adjustment (30%-80%) (FV-CSVK1)



**Flex-Z Fast®:** Single-hinged Flex-Z Fast® bracket provides flexible, fast and easy installation



**LED Lighting**

JA-8 compliant for CA Title 24/50,000 hours rated average life. Standard fan/light models feature a warm white LED light. All Architectural models feature a five color changing temperature LED light.

**Plug 'N Play Receptacles & Pick-A-Flow® Switch**



**SUGGESTED PRODUCTS**



**20/40/60 Control Switch** S16008WA

OR



**Auxiliary Control Switch** S16009WA



**Temperature, Humidity & Motion Sensor** W1006UWA



**Flex-Z Fast®**



**CALGreen**



**Flex-Z Fast®**



**CALGreen**



Specifications		WhisperGreen <sup>®</sup> Select (Fan Only)																																				
		Base Fan / Fan with built-in multi-speed																																				
		FV-0511VK3 / FV-0511VKS3																																				
Duct Diameter (inches)		6"																																				
Characteristics (HVI tested data for 0.1" S.P.)	Static Pressure in inches w.g.	0.1	0.25	0.375	0.5	0.1	0.25	0.375	0.5	0.1	0.25	0.375	0.5		0.1	0.25	0.375	0.5	0.1	0.25	0.375	0.5	0.1	0.25	0.375	0.5	0.1	0.25	0.375	0.5	0.1	0.25	0.375	0.5	0.1	0.25	0.375	0.5
	Air Volume (CFM)	110	110	110	109	100	100	100	100	90	90	90	90		80	80	80	80	70	70	70	70	60	60	60	60	50	50	50	50	40	40	40	40	30	30	30	30
	Noise (sones)	<0.3	0.3	---	---	<0.3	0.3	---	---	<0.3	0.3	---	---		<0.3	0.3	---	---	<0.3	0.3	---	---	<0.3	0.3	---	---	<0.3	0.4	---	---	<0.3	<0.3	---	---	<0.3	<0.3	---	---
	Power Consumption (watts)	6.7	12.1	17.0	23.0	5.5	10.5	15.4	20.5	4.9	9.7	14.3	19.3		4.4	9.2	13.2	17.6	4.0	8.2	12.2	16.3	3.6	7.4	11.1	15.0	3.4	7.0	9.9	13.3	3.0	6.2	8.7	12.0	2.8	5.5	7.9	11.4
	Energy Efficiency (CFM/Watt)	16.7	9.3	6.6	4.8	18.5	9.8	6.6	5.0	18.4	9.5	6.5	4.7		18.4	8.8	6.1	4.6	17.7	8.7	5.9	4.4	16.8	8.2	5.5	4.2	14.9	7.2	5.3	4.0	13.6	6.6	4.7	3.6	10.8	5.7	4.0	3.2
	Speed (RPM)	595	887	1089	1261	580	892	1097	1260	572	898	1102	1283		569	908	1109	1281	565	902	1121	1283	570	906	1120	1293	575	933	1127	1296	563	921	1126	1294	587	930	1123	1300
	Amps (Current)	0.11	0.20	0.27	0.36	0.10	0.18	0.25	0.32	0.09	0.17	0.24	0.31		0.08	0.16	0.22	0.28	0.08	0.14	0.20	0.27	0.07	0.13	0.19	0.24	0.07	0.12	0.17	0.22	0.06	0.11	0.15	0.20	0.06	0.10	0.14	0.19
	MAX. Amps (Current)	0.36																																				

Specifications		WhisperGreen <sup>®</sup> Select (Fan Only)																																				
		Base Fan / Fan with built-in multi-speed																																				
		FV-0511VK3 / FV-0511VKS3																																				
Duct Diameter (inches)		4"																																				
Characteristics (HVI tested data for 0.1" S.P.)	Static Pressure in inches w.g.	0.1	0.25	0.375	0.5	0.1	0.25	0.375	0.5	0.1	0.25	0.375	0.5		0.1	0.25	0.375	0.5	0.1	0.25	0.375	0.5	0.1	0.25	0.375	0.5	0.1	0.25	0.375	0.5	0.1	0.25	0.375	0.5	0.1	0.25	0.375	0.5
	Air Volume (CFM)	110	110	110	104	100	100	100	100	90	90	90	89		80	80	80	80	70	70	70	70	60	60	60	60	50	50	50	50	40	40	40	40	30	30	30	30
	Noise (sones)	<0.3	0.8	---	---	<0.3	0.7	---	---	<0.3	0.7	---	---		<0.3	0.7	---	---	<0.3	0.7	---	---	<0.3	0.7	---	---	<0.3	0.6	---	---	<0.3	0.6	---	---	<0.3	0.6	---	---
	Power Consumption (watts)	9.7	15.2	21.0	24.7	7.8	13.0	18.0	23.5	6.6	11.6	16.2	21.0		5.6	10.6	14.7	19.4	5.1	9.3	13.4	17.0	4.4	8.1	11.7	15.5	3.8	7.3	10.4	13.6	3.4	6.3	9.3	12.0	2.9	5.6	8.4	11.5
	Energy Efficiency (CFM/Watt)	11.5	7.3	5.3	4.2	12.9	7.8	5.6	4.3	13.6	7.7	5.6	4.2		14.2	7.7	5.4	4.1	14.0	7.6	5.3	4.2	13.8	7.6	5.2	3.9	13.5	7.0	5.0	3.8	12.9	6.9	4.6	3.6	10.5	5.7	3.8	3.0
	Speed (RPM)	782	1031	1214	1349	747	1007	1189	1349	714	993	1170	1333		684	985	1166	1340	672	964	1164	1317	654	956	1148	1324	630	946	1145	1313	619	938	1142	1299	606	939	1141	1304
	Amps (Current)	0.16	0.24	0.33	0.38	0.14	0.22	0.29	0.37	0.12	0.20	0.26	0.33		0.10	0.18	0.24	0.31	0.09	0.16	0.22	0.27	0.08	0.14	0.19	0.25	0.07	0.13	0.17	0.22	0.66	0.11	0.16	0.20	0.58	0.10	0.14	0.19
	MAX. Amps (Current)	0.66																																				

Specifications		WhisperGreen <sup>®</sup> Select (Fan Only)																																								
		Base Fan + Multi-speed module																																								
		FV-1115VK3 + FV-VS15VK1																																								
Duct Diameter (inches)		6"																																								
Characteristics (HVI tested data for 0.1" S.P.)	Static Pressure in inches w.g.	0.1	0.25	0.375	0.5	0.1	0.25	0.375	0.5	0.1	0.25	0.375	0.5	0.1	0.25	0.375	0.5	0.1	0.25	0.375	0.5	0.1	0.25	0.375	0.5	0.1	0.25	0.375	0.5	0.1	0.25	0.375	0.5	0.1	0.25	0.375	0.5					
	Air Volume (CFM)	150	150	148	121	130	130	128	120	120	120	110	110	110		109	100	100	100	100	90	90	90	90	80	80	80	80	70	70	70	70	60	60	60	60	50	50	50	50		
	Noise (sones)	<0.3	0.6	---	---	<0.3	0.5	---	---	<0.3	0.4	---	---	<0.3	0.3	---	---	<0.3	0.3	---	---	<0.3	0.3	---	---	<0.3	0.3	---	---	<0.3	0.3	---	---	<0.3	0.4							
	Power Consumption (watts)	11.6	17.4	23.5	24.4	8.8	14.8	20.0	25.0	7.5	13.0	18.5	24.4	6.7	12.1	17.0		23.0	5.5	10.5	15.4	20.5	4.9	9.7	14.3	19.3	4.4	9.2	13.2	17.6	4.0	8.2	12.2	16.3	3.6	7.4	11.1	15.0	3.4	7.0	10.4	13.3
	Energy Efficiency (CFM/Watt)	13.1	8.7	6.4	5.0	15.0	9.2	6.7	5.2	16.9	9.8	6.8	5.2	16.7	9.3	6.6		4.8	18.5	9.8	6.6	5.0	18.4	9.5	6.5	4.7	18.4	8.8	6.1	4.6	17.7	8.7	5.9	4.4	16.8	8.2	5.5	4.2	15.8	7.7	5.1	4.2
	Speed (RPM)	680	894	1082	1253	638	898	1091	1259	626	892	1098	1264	595	887	1089		1261	580	892	1097	1260	572	898	1102	1283	569	908	1109	1281	565	902	1121	1283	570	906	1120	1293	583	918	1131	1290
	Amps (Current)	0.19	0.27	0.36	0.38	0.15	0.24	0.32	0.39	0.14	0.22	0.30	0.39	0.11	0.20	0.27		0.36	0.10	0.18	0.25	0.32	0.09	0.17	0.24	0.31	0.08	0.16	0.22	0.28	0.08	0.14	0.20	0.27	0.07	0.13	0.19	0.24	0.07	0.12	0.18	0.22
	MAX. Amps (Current)	0.39																																								

Specifications		WhisperGreen <sup>®</sup> Select																																				
		Base Fan with multi-speed module																																				
		FV-0511VKS3S																																				
Duct Diameter (inches)		6"																																				
Characteristics (HVI tested data for 0.1" S.P.)	Static Pressure in inches w.g.	0.1	0.25	0.375	0.5	0.1	0.25	0.375	0.5	0.1	0.25	0.375	0.5		0.1	0.25	0.375	0.5	0.1	0.25	0.375	0.5	0.1	0.25	0.375	0.5	0.1	0.25	0.375	0.5	0.1	0.25	0.375	0.5	0.1	0.25	0.375	0.5
	Air Volume (CFM)	110	110	110	109	100	100	100	100	90	90	90	90		80	80	80	80	70	70	70	70	60	60	60	60	50	50	50	50	40	40	40	40	30	30	30	30
	Noise (sones)	<0.3	<0.3	---	---	<0.3	<0.3	---	---	<0.3	<0.3	---	---		<0.3	<0.3	---	---	<0.3	<0.3	---	---	<0.3	<0.3	---	---	<0.3	<0.3	---	---	<0.3	<0.3	---	---	<0.3	<0.3	---	---
	Power Consumption (watts)	7.4	12.9	18.1	23.8	6.2	11.2	16.6	21.7	5.4	10.6	15.0	19.8		4.7	9.5	13.2	18.1	4.3	8.6	12.4	16.7	3.9	7.7	11.0	15.0	3.4	7.2	10.3	13.4	3.1	6.2	9.1	12.4	2.9	5.6	8.2	11.6
	Energy Efficiency (CFM/Watt)	15.2	8.6	6.2	4.6	16.4	9.1	6.3	4.7	17.3	8.8	6.2	4.7		17.3	8.6	6.1	4.5	16.8	8.4	5.8	4.3	16.1	8.1	5.7	4.2	15.2	7.2	5.0	3.9	13.5	6.8	4.7	3.5	11.2	5.9	4.1	3.3
	Speed (RPM)	641	932	1120	1282	629	930	1129	1299	620	936	1127	1294		601	928	1111	1294	592	920	1122	1298	590	917	1118	1304	577	930	1130	1303	577	926	1147	1317	585	934	1130	1300
	Amps (Current)	0.12	0.21	0.28	0.37	0.11	0.19	0.27	0.34	0.10	0.18	0.25	0.32		0.09	0.16	0.22	0.29	0.08	0.15	0.21	0.27	0.07	0.13	0.19	0.24	0.07	0.12	0.17	0.22	0.06	0.11	0.15	0.20	0.06	0.10	0.14	0.19
	MAX. Amps (Current)	0.37																																				

Specifications		WhisperGreen <sup>®</sup> Select																																				
		Base Fan with multi-speed module																																				
		FV-0511VKS3S																																				
Duct Diameter (inches)		4"																																				
Characteristics (HVI tested data for 0.1" S.P.)	Static Pressure in inches w.g.	0.1	0.25	0.375	0.5	0.1	0.25	0.375	0.5	0.1	0.25	0.375	0.5		0.1	0.25	0.375	0.5	0.1	0.25	0.375	0.5	0.1	0.25	0.375	0.5	0.1	0.25	0.375	0.5	0.1	0.25	0.375	0.5	0.1	0.25	0.375	0.5
	Air Volume (CFM)	110	110	110	100	100	100	100	90	90	90	90		80	80	80	80	70	70	70	70	60	60	60	60	50	50	50	50	40	40	40	40	30	30	30	30	
	Noise (sones)	<0.3	0.6	---	---	<0.3	0.6	---	---	<0.3	0.5	---	---		<0.3	0.5	---	---	<0.3	0.5	---	---	<0.3	0.4	---	---	<0.3	0.4	---	---	<0.3	0.3	---	---	<0.3	0.3	---	---
	Power Consumption (watts)	10.7	16.5	22.1	24.8	8.3	14.2	18.8	23.9	7.1	12.4	17.1	21.7		6.2	11.1	15.1	19.6	5.4	9.8	13.8	17.5	4.7	8.5	11.5	15.8	4.0	7.8	10.9	13.9	3.3	6.3	9.1	12.4	3.0	5.8	8.5	11.6
	Energy Efficiency (CFM/Watt)	10.5	6.8	5.1	4.1	12.2	7.2	5.4	4.2	12.8	7.5	5.4	4.2		13.0	7.4	5.3	4.1	13.1	7.5	5.4	4.1	13.4	7.4	5.5	4.1	13.6	7.0	5.0	4.1	12.4	6.7	4.7	3.5	10.6	5.9	4.2	3.4
	Speed (RPM)	829	1077	1241	1365	783	1047	1212	1367	751	1022	1203	1352		726	1005	1192	1350	708	996	1184	1344	677	970	1155	1329	645	974	1172	1322	617	942	1149	1322	612	949	1147	1307
	Amps (Current)	0.18	0.26	0.34	0.38	0.15	0.23	0.30	0.37	0.12	0.21	0.28	0.34		0.11	0.19	0.25	0.31	0.10	0.17	0.23	0.29	0.09	0.15	0.20	0.26	0.08	0.14	0.19	0.24	0.07	0.11	0.16	0.21	0.06	0.11	0.15	0.20
	MAX. Amps (Current)	0.38																																				

Specifications		WhisperGreen <sup>®</sup> Select (Fan + Light)																																				
		Base fan with multi-speed + 5 CCT LED Light + Night Light																																				
		FV-0511VKSL3K																																				
Duct Diameter (inches)		6"																																				
Characteristics (HVI tested data for 0.1" S.P.)	Static Pressure in inches w.g.	0.1	0.25	0.375	0.5	0.1	0.25	0.375	0.5	0.1	0.25	0.375	0.5		0.1	0.25	0.375	0.5	0.1	0.25	0.375	0.5	0.1	0.25	0.375	0.5	0.1	0.25	0.375	0.5	0.1	0.25	0.375	0.5	0.1	0.25	0.375	0.5
	Air Volume (CFM)	110	110	110	106	100	100	100	100	90	90	90	90		80	80	80	80	70	70	70	70	60	60	60	60	50	50	50	50	40	40	40	40	30	30	30	30
	Noise (sones)	<0.3	<0.3	---	---	<0.3	0.3	---	---	<0.3	<0.3	---	---		<0.3	<0.3	---	---	<0.3	<0.3	---	---	<0.3	<0.3	---	---	<0.3	<0.3	---	---	<0.3	<0.3	---	---	<0.3	<0.3	---	---
	Power Consumption (watts)	7.1	12.4	18.1	22.7	6.1	11.7	16.5	21.9	5.5	10.6	15.2	19.4		4.8	9.5	13.7	17.9	4.5	8.7	12.7	16.5	4.0	8.0	11.4	14.7	3.7	7.2	10.1	13.5	3.2	6.2	9.2	12.6	3.0	5.8	8.5	11.6
	Energy Efficiency (CFM/Watt)	15.6	8.9	6.2	4.7	16.5	8.6	6.1	4.6	16.4	8.5	6.0	4.7		16.9	8.5	5.9	4.5	15.8	8.2	5.6	4.3	15.3	7.7	5.3	4.2	13.7	7.2	5.3	4.1	13.2	7.0	4.8	3.6	10.7	5.7	4.2	3.2
	Speed (RPM)	644	945	1138	1304	621	948	1132	1297	614	943	1131	1296		608	933	1126	1298	610	928	1139	1300	611	946	1143	1292	610	937	1132	1301	589	929	1139	1322	599	950	1148	1309
	Amps (Current)	0.12	0.21	0.30	0.36	0.11	0.19	0.26	0.34	0.10	0.18	0.24	0.31		0.09	0.16	0.22	0.28	0.08	0.15	0.21	0.27	0.08	0.14	0.19	0.24	0.07	0.13	0.17	0.23	0.06	0.11	0.16	0.21	0.06	0.10	0.15	0.20
	MAX. Amps (Current)	0.36																																				

Specifications		WhisperGreen <sup>®</sup> Select (Fan + Light)																																				
		Base fan with multi-speed + 5 CCT LED Light + Night Light																																				
		FV-0511VKSL3K																																				
Duct Diameter (inches)		4"																																				
Characteristics (HVI tested data for 0.1" S.P.)	Static Pressure in inches w.g.	0.1	0.25	0.375	0.5	0.1	0.25	0.375	0.5	0.1	0.25	0.375	0.5		0.1	0.25	0.375	0.5	0.1	0.25	0.375	0.5	0.1	0.25	0.375	0.5	0.1	0.25	0.375	0.5	0.1	0.25	0.375	0.5	0.1	0.25	0.375	0.5
	Air Volume (CFM)	110	110	110	100	100	100	100	90	90	90	90		80	80	80	80	70	70	70	70	60	60	60	60	50	50	50	50	40	40	40	40	30	30	30	30	
	Noise (sones)	<0.3	0.6	---	---	<0.3	0.6	---	---	<0.3	0.5	---	---		<0.3	0.5	---	---	<0.3	0.4	---	---	<0.3	0.4	---	---	<0.3	0.4	---	---	<0.3	0.3	---	---	<0.3	0.3	---	---
	Power Consumption (watts)	10.7	16.5	22.1	24.8	8.7	14.6	19.1	24.3	7.2	12.6	17.2	21.9		6.4	11.2	15.1	19.7	5.6	9.6	14.0	17.8	4.6	8.5	11.7	15.7	3.9	7.5	10.4	13.7	3.4	6.5	9.4	12.4	2.9	5.7	8.3	11.7
	Energy Efficiency (CFM/Watt)	10.3	6.7	5.1	4.0	11.7	7.0	5.3	4.2	12.7	7.4	5.4	4.2		12.6	7.3	5.3	4.1	12.6	7.4	5.1	3.9	13.2	7.1	5.1	4.0	13.0	6.7	4.9	3.7	12.5	6.5	4.6	3.4	11.0	5.6	3.8	2.7
	Speed (RPM)	834	1079	1240	1373	801	1060	1223	1372	759	1031	1203	1360		735	1008	1188	1354	712	981	1187	1342	675	977	1163	1327	628	959	1152	1319	612	950	1148	1312	605	940	1140	1310
	Amps (Current)	0.17	0.26	0.34	0.38	0.15	0.24	0.31	0.38	0.13	0.21	0.28	0.35		0.11	0.19	0.25	0.32	0.10	0.16	0.23	0.28	0.09	0.15	0.20	0.25	0.07	0.13	0.18	0.23	0.07	0.12	0.16	0.21	0.06	0.10	0.14	0.19
	MAX. Amps (Current)	0.38																																				

Specifications		WhisperGreen <sup>®</sup> Select (Fan + Light)																																								
		Base fan /Fan with multi-speed +Warm White LED Light + Night Light																																								
		FV-1115VKL3																																								
Duct Diameter (inches)		6"																																								
Characteristics (HVI tested data for 0.1" S.P.)	Static Pressure in inches w.g.	0.1	0.25	0.375	0.5	0.1	0.25	0.375	0.5	0.1	0.25	0.375	0.5		0.5	0.1	0.25	0.375	0.5	0.1	0.25	0.375	0.5	0.1	0.25	0.375	0.5	0.1	0.25	0.375	0.5	0.1	0.25	0.375	0.5	0.1	0.25	0.375	0.5			
	Air Volume (CFM)	150	150	147	115	130	130	130	117	120	120	119	115	110	110		108	100	100	100	99	90	90	90	89	80	80	80	77	70	70	70	70	60	60	60	60	50	50	50	50	
	Noise (sones)	0.4	0.8	---	---	<0.3	0.5	---	---	<0.3	0.4	---	---	<0.3	0.3	---	<0.3	0.3	---	---	<0.3	0.3	---	---	<0.3	0.3	---	---	<0.3	0.3	---	---	<0.3	0.3	---	---	<0.3	0.3	---	---		
	Power Consumption (watts)	12.5	19.2	24.4	24.3	9.6	15.8	21.3	24.2	8.1	13.7	18.6	23.8	6.9	12.3	17.4		22.8	6.2	11.4	16.5	20.7	5.3	10.4	15.1	19.5	4.7	9.4	13.7	18.2	4.2	8.5	12.8	17.0	4.0	7.7	11.6	15.2	3.5	7.1	10.3	13.6
	Energy Efficiency (CFM/Watt)	12.1	7.9	6.0	4.8	13.7	8.6	6.2	4.9	15.1	9.1	6.5	4.9	16.4	9.3	6.6		4.8	16.7	9.2	6.5	4.9	17.5	9.0	6.3	4.7	17.4	9.0	6.2	4.3	16.9	8.4	5.6	4.2	15.6	8.1	5.4	4.1	14.9	7.3	5.2	4.0
	Speed (RPM)	729	959	1132	1289	677	944	1136	1288	657	931	1127	1298	635	930	1120		1291	633	930	1125	1282	604	927	1123	1292	595	920	1124	1305	586	916	1134	1312	602	921	1136	1305	582	929	1133	1310
	Amps (Current)	0.21	0.3	0.39	0.39	0.16	0.26	0.34	0.38	0.14	0.23	0.31	0.38	0.13	0.21	0.29		0.36	0.12	0.2	0.27	0.34	0.1	0.17	0.25	0.31	0.08	0.16	0.22	0.28	0.08	0.15	0.21	0.27	0.07	0.14	0.19	0.25	0.07	0.12	0.17	0.22
	MAX. Amps (Current)	0.39																																								

Specifications		WhisperGreen <sup>®</sup> Select (Fan + Light)																																				
		Base Fan / Fan with multi-speed + Warm White LED Light + Night Light																																				
		FV-0511VKL3 / FV-0511VKSL3																																				
Duct Diameter (inches)		6"																																				
Characteristics (HVI tested data for 0.1" S.P.)	Static Pressure in inches w.g.	0.1	0.25	0.375	0.5	0.1	0.25	0.375	0.5	0.1	0.25	0.375	0.5		0.1	0.25	0.375	0.5	0.1	0.25	0.375	0.5	0.1	0.25	0.375	0.5	0.1	0.25	0.375	0.5	0.1	0.25	0.375	0.5	0.1	0.25	0.375	0.5
	Air Volume (CFM)	110	110	107	104	100	100	100	100	90	90	90	90		80	80	80	80	70	70	70	70	60	60	60	60	50	50	50	50	40	40	40	40	30	30	30	30
	Noise (sones)	<0.3	0.3	---	---	<0.3	0.3	---	---	<0.3	0.3	---	---		<0.3	0.3	---	---	<0.3	0.3	---	---	<0.3	0.3	---	---	<0.3	0.3	---	---	<0.3	0.3	---	---	<0.3	<0.3	---	---
	Power Consumption (watts)	7.2	12.6	18.1	22.7	6.0	11.4	16.5	21.6	5.3	10.4	15.0	19.7		4.6	9.4	13.5	18.2	4.2	8.5	12.5	16.4	3.9	8.0	11.3	15.4	3.5	7.2	10.1	13.7	3.2	6.3	9.0	12.6	2.9	5.6	8.5	11.7
	Energy Efficiency (CFM/Watt)	15.7	9.0	6.0	4.7	17.5	9.3	6.6	4.9	18.0	9.2	6.5	4.8		18.2	9.1	6.3	4.8	17.8	8.8	6.0	4.6	15.5	7.6	5.4	4.0	14.9	7.2	5.3	4.0	13.3	6.8	4.8	3.5	11.0	5.8	3.9	3.0
	Speed (RPM)	636	915	1123	1285	621	934	1126	1290	605	930	1122	1294		591	922	1121	1292	588	920	1129	1292	595	935	1131	1311	587	937	1130	1314	586	934	1138	1325	595	938	1155	1304
	Amps (Current)	0.12	0.20	0.28	0.35	0.11	0.19	0.27	0.35	0.10	0.18	0.25	0.32		0.09	0.17	0.23	0.30	0.08	0.15	0.21	0.27	0.07	0.14	0.19	0.25	0.07	0.13	0.17	0.22	0.06	0.11	0.16	0.21	0.06	0.10	0.15	0.20
	MAX. Amps (Current)	0.35																																				

Specifications		WhisperGreen <sup>®</sup> Select (Fan + Light)																																				
		Base Fan / Fan with multi-speed + Warm White LED Light + Night Light																																				
		FV-0511VKL3 / FV-0511VKSL3																																				
Duct Diameter (inches)		4"																																				
Characteristics (HVI tested data for 0.1" S.P.)	Static Pressure in inches w.g.	0.1	0.25	0.375	0.5	0.1	0.25	0.375	0.5	0.1	0.25	0.375	0.5		0.1	0.25	0.375	0.5	0.1	0.25	0.375	0.5	0.1	0.25	0.375	0.5	0.1	0.25	0.375	0.5	0.1	0.25	0.375	0.5	0.1	0.25	0.375	0.5
	Air Volume (CFM)	110	110	110	99	100	100	100	100	90	90	90	90		80	80	80	80	70	70	70	70	60	60	60	60	50	50	50	50	40	40	40	40	30	30	30	30
	Noise (sones)	<0.3	0.7	---	---	<0.3	0.7	---	---	<0.3	0.7	---	---		<0.3	0.7	---	---	<0.3	0.7	---	---	<0.3	0.6	---	---	<0.3	0.6	---	---	<0.3	0.5	---	---	<0.3	0.4	---	---
	Power Consumption (watts)	10.5	16.3	22.1	24.8	8.6	13.9	19.2	24.3	7.2	12.7	17.0	21.9		6.4	11.1	15.0	18.8	5.3	9.6	13.8	17.7	4.7	8.3	11.9	15.8	3.9	7.4	10.7	14.2	3.5	6.4	9.7	13.0	3.1	5.9	9.2	12.0
	Energy Efficiency (CFM/Watt)	10.8	7.0	5.1	4.1	12.2	7.6	5.5	4.3	13.1	7.6	5.6	4.3		13.0	7.6	5.5	4.4	13.3	7.4	5.5	4.0	12.9	7.3	5.1	3.9	13.1	6.8	5.0	3.8	11.9	6.5	4.7	3.5	10.0	5.3	3.6	2.9
	Speed (RPM)	824	1069	1244	1373	793	1039	1222	1370	754	1033	1199	1359		722	1004	1187	1342	693	983	1184	1343	672	966	1169	1331	643	961	1158	1334	628	955	1165	1338	623	969	1158	1327
	Amps (Current)	0.17	0.26	0.34	0.38	0.15	0.23	0.31	0.38	0.13	0.21	0.28	0.35		0.11	0.18	0.25	0.30	0.10	0.16	0.23	0.28	0.09	0.14	0.20	0.26	0.07	0.13	0.18	0.23	0.07	0.11	0.16	0.21	0.06	0.11	0.15	0.20
	MAX. Amps (Current)	0.38																																				

**FV-0511VQC1** 50-80-110 CFM 4" or 6" Duct  
**FV-0511VQCL1** 50-80-110 CFM 4" or 6" Duct



7-3/8" Depth

**KEY FEATURES**

- Precision spot ventilation fans ideal for use in the bathroom, laundry room, basement or garage
- Revolutionary ECM motor with SmartFlow™ technology for optimum CFM output
- Pick-A-Flow® Airflow Selector (50-80-110 CFM) combined with SmartFlow™ Technology simplifies the selection process and ensures optimum performance to meet code and reduce callbacks
- Dual Sensor Technology (motion & moisture) provides built-in redundancy for the ultimate in automatic moisture and odor control
- Single-hinged Flex-Z Fast® bracket provides flexible, fast & trouble-free installation, even from below the ceiling
- Lighted model(FV-0511VQCL1) incorporates one 10W dimmable LED chip panel with <1W LED night light for warm, long-life energy efficient illumination (night light must be wired separately)



Built-in Controls

**Three ways the fan can function**

- Motion on/motion off
- Motion on/humidity off
- Humidity on/humidity off
- Variable humidity controls from 30-80% relative humidity (RH)
- Adjustable delay timer from 30 seconds to 60 minutes



Pick-A-Flow® Airflow Selector Switch



Flex-Z Fast®

**LED Lighting**

INCLUDES: 10W Dimmable LED chip panel with <1W LED night/3000 Kelvin Warm White/90CRI/700 lumens/70 LPW/JA8 compliant for CA Title 24/50,000 hours rated average life.



**SUGGESTED PRODUCTS**

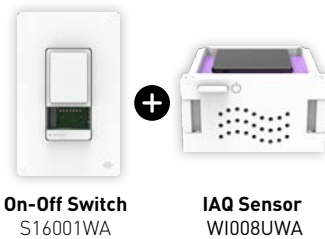

On-Off Switch S16001WA

IAQ Sensor WI008UWA

WhisperSense DC Characteristics	FV-0511VQC1								FV-0511VQCL1 (Fan/Light)									
	0.1	0.25	0.375	0.1	0.25	0.375	0.1	0.25	0.375	0.1	0.25	0.375	0.1	0.25	0.375	0.1	0.25	0.375
Static pressure in inches w.g.	0.1	0.25	0.375	0.1	0.25	0.375	0.1	0.25	0.375	0.1	0.25	0.375	0.1	0.25	0.375	0.1	0.25	0.375
Air Volume (CFM)	110	111	91	80	83	82	50	53	53	110	110	86	80	83	82	50	50	44
Noise (sones)	<0.3	0.9	-	<0.3	0.6	-	<0.3	0.4	-	0.4	0.9	-	<0.3	0.6	-	<0.3	0.4	-
Power Consumption (Watts)	10.6	16.4	17.1	5.9	10.8	14.5	4.0	7.2	10.5	10.9	16.1	16.8	6.0	11.0	14.6	3.9	7.1	10.0
Energy Efficiency (CFMs/Watt)	10.6	6.9	5.3	13.6	7.7	5.7	12.5	7.4	5.1	10.3	7.0	5.1	13.7	7.7	5.6	14.1	7.8	4.4
Speed	957	1239	1382	821	1172	1351	756	1093	1195	1016	1268	1398	867	1185	1370	768	1097	1315
Amps (Current)	0.18	0.26	0.27	0.11	0.18	0.24	0.07	0.13	0.18	0.18	0.26	0.26	0.11	0.19	0.24	0.07	0.12	0.17
Power Rating (V/Hz)	120/60		120/60		120/60		120/60		120/60		120/60		120/60		120/60		120/60	

**FV-0511VQ1** 50-80-110 CFM 4" or 6" Duct  
**FV-0511VQL1** 50-80-110 CFM 4" or 6" Duct  
**FV-1115VQ1** 110-130-150 CFM 6" Duct  
**FV-1115VQL1** 110-130-150 CFM 6" Duct



7-3/8" Depth

**KEY FEATURES**

- Precision spot ventilation fans ideal for use in the bathroom, laundry room, basement or garage
- Revolutionary ECM motor with SmartFlow™ technology ensures optimal CFM output
- Powerful CFM output overcomes 0.375" static pressure to assure code compliant, healthy homes
- Pick-A-Flow® airflow selector (50-80-110 or 110-130-150 CFM models) combined with SmartFlow™ technology simplifies the selection process and ensures optimum performance to meet code and reduce callbacks
- Lighted Models (FV-0511VQL1 / FV-1115VQL1) incorporate one 10W dimmable LED chip panel with <1W LED night light for warm, long-life energy efficient illumination (night light must be wired separately)
- Single-hinged Flex-Z Fast® bracket provides flexible, fast and easy installation



Pick-A-Flow® Airflow Selector Switch



Flex-Z Fast®

**LED Lighting**

INCLUDES: 10W Dimmable LED chip panel with <1W LED night light/3000 Kelvin Warm White/90CRI/700 lumens/70 LPW/JA8 compliant for CA Title 24/50,000 hours rated average.



WhisperCeiling DC Characteristics	FV-0511VQL1 (Fan/Light)								FV-1115VQL1 (Fan/Light)									
	0.1	0.25	0.375	0.1	0.25	0.375	0.1	0.25	0.375	0.1	0.25	0.375	0.1	0.25	0.375	0.1	0.25	0.375
Static pressure in inches w.g.	0.1	0.25	0.375	0.1	0.25	0.375	0.1	0.25	0.375	0.1	0.25	0.375	0.1	0.25	0.375	0.1	0.25	0.375
Air Volume (CFM)	110	110	86	80	83	82	50	50	44	150	144	80	130	131	79	110	110	78
Noise (sones)	0.4	0.9	-	<0.3	0.6	-	<0.3	0.4	-	0.5	0.8	-	<0.3	0.7	-	<0.3	0.5	-
Power Consumption (Watts)	10.9	16.1	16.8	6.0	11.0	14.6	3.9	7.1	10.0	13.0	19.3	14.5	10.3	17.0	14.5	7.7	12.8	14.6
Energy Efficiency (CFMs/Watt)	10.3	7.0	5.1	13.7	7.7	5.6	14.1	7.8	4.4	11.7	7.5	5.5	12.8	7.8	5.4	14.5	8.7	5.3
Speed	1016	1268	1398	867	1185	1370	768	1097	1315	740	958	1124	722	949	1127	679	935	1126
Amps (Current)	0.18	0.26	0.26	0.11	0.19	0.24	0.07	0.12	0.17	0.21	0.30	0.24	0.17	0.27	0.23	0.13	0.22	0.23
Power Rating (V/Hz)	120/60		120/60		120/60		120/60		120/60		120/60		120/60		120/60		120/60	

WhisperCeiling DC Characteristics	FV-0511VQ1								FV-1115VQ1									
	0.1	0.25	0.375	0.1	0.25	0.375	0.1	0.25	0.375	0.1	0.25	0.375	0.1	0.25	0.375	0.1	0.25	0.375
Static pressure in inches w.g.	0.1	0.25	0.375	0.1	0.25	0.375	0.1	0.25	0.375	0.1	0.25	0.375	0.1	0.25	0.375	0.1	0.25	0.375
Air Volume (CFM)	110	111	91	80	83	82	50	53	53	150	152	85	130	131	85	110	110	85
Noise (sones)	<0.3	0.9	-	<0.3	0.6	-	<0.3	0.4	-	<0.3	0.7	-	<0.3	0.5	-	<0.3	<0.3	-
Power Consumption (Watts)	10.6	16.4	17.1	5.9	10.8	14.5	4.0	7.2	10.5	11.8	20.2	15.0	9.0	15.7	15.0	6.8	12.1	15.0
Energy Efficiency (CFMs/Watt)	10.6	6.9	5.3	13.6	7.7	5.7	12.5	7.4	5.1	12.9	7.6	5.7	14.7	8.5	5.7	16.4	9.2	5.7
Speed	957	1239	1382	821	1172	1351	756	1093	1195	698	925	1110	671	918	1108	636	900	1112
Amps (Current)	0.18	0.26	0.27	0.11	0.18	0.24	0.07	0.13	0.18	0.19	0.31	0.25	0.16	0.25	0.25	0.12	0.20	0.25
Power Rating (V/Hz)	120/60		120/60		120/60		120/60		120/60		120/60		120/60		120/60		120/60	



**SUGGESTED PRODUCTS**



On-Off Switch S16001WA

IAQ Sensor WI008UWA



**FV-20VQ3** 190 CFM 6" Duct  
**FV-30VQ3** 290 CFM 6" Duct  
**FV-40VQ4\*** 390 CFM 6" Duct



**KEY FEATURES**

- Large volume (190-390) CFM options designed for light commercial applications
- AC motor
- UL listed for tub/shower enclosure when GFCI protected
- Complies with with ASHRAE 62.2, Indoor airPlus, EarthCraft and California Title 24

\*FV-40VQ4 does not comply with the ENERGY STAR® 4.1 requirement for increased efficiency (CFM/Watt).

WhisperCeiling (AC)		FV-20VQ3		FV-30VQ3		FV-40VQ4*	
Characteristics							
Static pressure in inches w.g.		0.1	0.25	0.1	0.25	0.1	0.25
Air Volume (CFM)		190	145	290	257	390	356
Noise (sones)		0.8	-	2.0	-	3.0	-
Power Consumption (Watts)		44.5	43.6	64.0	62.0	111.4	109.6
Energy Efficiency (CFMs/Watt)		4.6	3.6	4.5	4.1	3.5	3.3
Speed		761	949	877	990	793	874
Amps (Current)		0.34	0.33	0.53	0.52	0.99	0.98
Power Rating (V/Hz)		120/60		120/60		120/60	

**FV-08VRE2** 80 CFM 4" or 6" Duct



**KEY FEATURES**

- Beautiful lighting with 6" aperture and advanced luminaire design
- Includes (1) replaceable, 8W ENERGY STAR 2.0 certified, GU24 base LED lamp, JA-8 compliant for CA Title 24 and Title 20
- Quiet, energy efficient and powerful 80 CFM ventilation hidden above the ceiling
- Ideal for use in the bathroom, living room or laundry room
- Complies with ASHRAE 62.2, CALGreen\*, Indoor airPlus and JA8 compliant for CA Title24 & Title20

\*Complies with with CALGreen when controlled by the Panasonic Condensation Sensor Plus



**LED Lighting**

INCLUDES: 8 Watt GU24 base LED lamp, /2700 Kelvin Warm White/>92CRI/720 lumens/90 LPW/ JA-8 compliant for CA Title 24 and Title 20, 25,000 rated average life.

WhisperRecessed LED		FV-08VRE2	
Characteristics			
Static pressure in inches w.g.		0.1	0.25
Air Volume (CFM)		80	66
Noise (sones)		1.0	0.8
Power Consumption (Watts)		18.5	17.6
Energy Efficiency (CFMs/Watt)		4.4	3.8
Speed		1342	1480
Amps (Current)		0.15	0.15
Power Rating (V/Hz)		120/60	

**SWDGET**

**SUGGESTED PRODUCTS**



**Ideal Retrofit Fan**

**FV-0511VF1** 50, 80, or 110 CFM 4" or 3" Duct Fan Only Model

**FV-0511VFL1** 50, 80 or 110 CFM 4" or 3" Duct Fan / Dimmable LED & Night light

**FV-0511VFC1** 50, 80 or 110 CFM 4" or 3" Duct Fan / Condensation Model

**KEY FEATURES**

- Revolutionary ECM motor with SmartFlow™ Technology ensures optimal CFM output
- Built-in Pick-A-Flow® airflow selector allows you to select your required airflow of 50, 80, or 110 CFM with a simple flip of a switch
- Condensation Sensor model (FV-0511VFC1) provides hands-free operation and automatic moisture control
- Lighted model (FV-0511VFL1) incorporates one 10W dimmable LED chip panel with <1W LED night light for warm, long-life energy efficient illumination (night light must be wired separately)
- Single-hinged Flex-Z Fast® bracket provides flexible, fast and easy installation
- Complies with ASHRAE 62.2, IAP and California Title 24



5-5/8" Depth  
(with 3" duct adapter)



Pick-A-Flow® Airflow Selector Switch



INCLUDED: 4" to 3" Duct Adapter



Flex-Z Fast®: Single-hinged bracket

**Installation is as Easy as 1-2-3!**



Insert single-hinged Flex-Z Fast® installation bracket



Connect the wiring and attach duct to installation adapter



Install Fan



**LED Lighting**

Includes 10 Watt dimmable LED chip panel/3000 Kelvin Warm White/90 CRI/700 lumens/70 LPW/JA8 compliant for CA Title 24/50,000 hours rated average life / <1W LED night light.

WhisperFit DC Characteristics	FV-0511VF1																	
	4"			4"			4"			3"			3"			3"		
Static Pressure in inches w.g.	0.1	0.25	0.375	0.1	0.25	0.375	0.1	0.25	0.375	0.1	0.25	0.375	0.1	0.25	0.375	0.1	0.25	0.375
Air Volume (CFM)	110	111	109	80	80	84	50	50	50	110	94	69	80	81	67	50	51	55
Noise (sones)	0.8	1.2	-	0.3	0.8	-	<0.3	0.4	-	2.0	1.5	-	0.8	1.4	-	<0.3	0.9	-
Power Consumption (watts)	10.2	14.6	17.9	5.9	9.4	13.2	4.0	7.1	10.0	17.1	16.4	13.6	8.8	13.0	13.5	4.6	7.7	10.8
Energy Efficiency (CFM/Watt)	11.0	7.7	6.2	13.9	8.7	6.5	13.5	7.6	5.4	6.6	5.9	5.2	9.4	6.5	5.2	11.5	7.0	5.3
Speed (RPM)	977	1222	1392	820	1142	1349	795	1152	1374	1341	1429	1476	1094	1357	1476	870	1205	1426
Current (amps)	0.18	0.24	0.28	0.11	0.16	0.22	0.08	0.13	0.17	0.27	0.26	0.22	0.15	0.21	0.22	0.09	0.14	0.18
Power Rating (V/Hz)	120/60																	

WhisperFit DC Characteristics	FV-0511VFL1																	
	4"			4"			4"			3"			3"			3"		
Static Pressure in inches w.g.	0.1	0.25	0.375	0.1	0.25	0.375	0.1	0.25	0.375	0.1	0.25	0.375	0.1	0.25	0.375	0.1	0.25	0.375
Air Volume (CFM)	110	110	100	80	82	83	50	51	52	110	89	64	80	80	62	50	51	52
Noise (sones)	1.0	1.3	-	0.3	0.7	-	<0.3	0.4	-	1.5	1.4	-	0.7	1.3	-	<0.3	0.7	-
Power Consumption (watts)	11.0	15.0	16.4	6.6	10.4	13.8	4.2	7.4	10.0	17.4	15.1	12.6	9.3	13.4	12.5	4.9	8.0	10.5
Energy Efficiency (CFM/Watt)	10.2	7.5	6.2	12.4	8.1	6.1	12.5	7.2	5.5	6.4	6.0	5.1	8.9	6.2	5.1	10.8	6.8	5.2
Speed (RPM)	999	1243	1399	890	1207	1400	833	1181	1396	1376	1431	1476	1135	1392	1481	907	1233	1444
Current (amps)	0.18	0.25	0.27	0.12	0.18	0.22	0.08	0.13	0.17	0.28	0.24	0.21	0.16	0.22	0.21	0.09	0.14	0.18
Power Rating (V/Hz)	120/60																	

WhisperFit DC Characteristics	FV-0511VFC1																	
	4"			4"			4"			3"			3"			3"		
Static Pressure in inches w.g.	0.1	0.25	0.375	0.1	0.25	0.375	0.1	0.25	0.375	0.1	0.25	0.375	0.1	0.25	0.375	0.1	0.25	0.375
Air Volume (CFM)	110	111	109	80	80	84	50	50	50	110	94	69	80	81	67	50	51	55
Noise (sones)	0.8	1.2	-	0.3	0.8	-	<0.3	0.4	-	2.0	1.5	-	0.8	1.4	-	<0.3	0.9	-
Power Consumption (watts)	10.2	14.6	17.9	5.9	9.4	13.2	4.0	7.1	10.0	17.1	16.4	13.6	8.8	13.0	13.5	4.6	7.7	10.8
Energy Efficiency (CFM/Watt)	11.0	7.7	6.2	13.9	8.7	6.5	13.5	7.6	5.4	6.6	5.9	5.2	9.4	6.5	5.2	11.5	7.0	5.3
Speed (RPM)	977	1222	1392	820	1142	1349	795	1152	1374	1341	1429	1476	1094	1357	1476	870	1205	1426
Current (amps)	0.18	0.24	0.28	0.11	0.16	0.22	0.08	0.13	0.17	0.27	0.26	0.22	0.15	0.21	0.22	0.09	0.14	0.18
Power Rating (V/Hz)	120/60																	



**SUGGESTED PRODUCTS**



20/40/60 Control Switch S16008WA



Temperature, Humidity & Motion Sensor WI006UWA



On-Off Switch S16001WA



Temperature, Humidity & Motion Sensor WI006UWA



**FV-0510VS1** 50-80-100 CFM 4" Oval Duct  
**FV-0510VSC1** 50-80-100 CFM 4" Oval Duct  
**FV-0810VSS1** 80 or 100 CFM 4" Oval Duct



3-3/8" Depth

**KEY FEATURES**

- 3-3/8" Housing Depth – lowest profile ENERGY STAR® fan available – fits anywhere
- Pick-A-Flow® Airflow Selector (50, 80 or 100 CFM) combined with SmartFlow™ technology simplifies the selection process and ensures optimum performance to meet code and reduce callbacks
- Optional built-in multi-speed Control for ASHRAE 62.2 compliance<sup>2</sup>
- Optional built-in condensation sensor to control moisture in the bathroom<sup>3</sup>

**WhisperValue DC Contractor Pack\***

The Contractor Pack includes four complete fans. The housing and motor/grille are packaged separately for flexibility during installation.

Housing Can	Motor/Grille Assembly	Complete Fan Unit	Master Pack
FV-0510VSA1	FV-0510VSB1	FV-0510VS1	4

\*Must order in quantities of 4, shipment will contain 1 box with 4 units.

**Transfer Register Box FV-JD**



- Designed for use with WhisperValue DC fan/light combinations
- Perfect for room-to-room powered circulation in multi-family projects with ductless heat pumps and mini splits
- Powered 50 CFM transfer at less than 0.3 sone (based on FV-0510VS1)
- 26 gauge steel, fire code rated accessory, sold separately as model
- No need for a radiation damper like on jump ducts
- Works with standard size HVAC registers – 4" x 10" HVAC supply grille
- Complies with ASHRAE 62.2, CALGreen and ENERGY STAR®



Pick-A-Flow® Airflow Selector Switch



Condensation Sensor RH sensitivity (30% – 80% RH) adjustment (FV-0510VSC1 Only)



Optional 4" Oval to 3" Round Duct Adapter (Model #: FV-VS43R)



Optional Multi-Speed Control

WhisperValue DC Characteristics	FV-0810VSS1																				
	4" Oval Duct			4" Oval Duct			4" Oval Duct			4" Oval Duct			4" Oval Duct			4" Oval Duct			4" Oval Duct		
Static pressure in inches w.g.	0.1	0.25	0.375	0.1	0.25	0.375	0.1	0.25	0.375	0.1	0.25	0.375	0.1	0.25	0.375	0.1	0.25	0.375	0.1	0.25	0.375
Air Volume (CFM)	100	101	83	80	81	75	70	72	70	60	64	65	50	52	52	40	41	42	30	31	30
Noise (sones)	0.9	1.3	-	0.4	0.8	-	<0.3	0.6	-	<0.3	0.6	-	<0.3	0.5	-	<0.3	0.5	-	<0.3	0.5	-
Power Consumption (Watts)	13.4	18.5	18.0	8.5	13.2	16.0	6.5	10.8	15.0	5.3	9.3	13.0	4.5	7.7	12.0	3.8	6.7	10.0	3.4	6.0	9.0
Energy Efficiency (CFMs/Watt)	7.5	5.5	4.6	10.0	6.5	4.7	11.2	6.9	4.7	11.8	7.2	5.0	12.1	7.3	4.3	11.8	6.9	4.2	10.2	6.0	3.3
Speed (RPM)	970	1197	1300	856	1114	1270	805	1088	1260	770	1076	1250	733	1050	1230	723	1037	1215	711	1033	1200
Amps (Current)	0.22	0.29	0.25	0.13	0.20	0.24	0.10	0.16	0.22	0.09	0.15	0.20	0.08	0.13	0.17	0.07	0.11	0.15	0.06	0.10	0.13
Power Rating (V/Hz)	120/60			0.25			120/60			120/60			120/60			120/60			120/60		

WhisperValue DC Characteristics	FV-0510VSC1								
	4" Oval Duct			4" Oval Duct			4" Oval Duct		
Static pressure in inches w.g.	0.1	0.25	0.375	0.1	0.25	0.375	0.1	0.25	0.375
Air Volume (CFM)	100	101	83	80	81	75	50	52	52
Noise (sones)	0.9	1.3	-	0.4	0.8	-	<0.3	0.5	-
Power Consumption (Watts)	13.4	18.5	18.0	8.5	13.2	16.0	4.5	7.7	12.0
Energy Efficiency (CFMs/Watt)	7.5	5.5	4.6	10.0	6.5	4.7	12.1	7.3	4.3
Speed (RPM)	970	1197	1300	856	1114	1270	733	1050	1230
Amps (Current)	0.22	0.29	0.25	0.13	0.20	0.24	0.08	0.13	0.17
Power Rating (V/Hz)	120/60			120/60			120/60		

WhisperValue DC Characteristics	FV-0510VS1								
	4" Oval Duct			4" Oval Duct			4" Oval Duct		
Static pressure in inches w.g.	0.1	0.25	0.375	0.1	0.25	0.375	0.1	0.25	0.375
Air Volume (CFM)	100	100	83	80	81	75	50	53	52
Noise (sones)	0.9	1.3	-	0.4	0.8	-	<0.3	0.5	-
Power Consumption (Watts)	11.1	16.0	18.0	7.2	11.5	16.0	4.4	7.5	12.0
Energy Efficiency (CFMs/Watt)	9.2	6.4	4.6	11.4	7.2	4.7	12.8	7.9	4.3
Speed (RPM)	902	1121	1300	797	1070	1270	708	1025	1230
Amps (Current)	0.20	0.27	0.25	0.13	0.20	0.24	0.09	0.14	0.17
Power Rating (V/Hz)	120/60			120/60			120/60		



**FV-0510VSL1** 50-80-100 CFM 4" Oval Duct  
**FV-0810VSSL1** 80 or 100 CFM 4" Oval Duct  
**FV-0510VSCL1** 50-80-100 CFM 4" Oval Duct



3-3/8" Depth



**KEY FEATURES\*:**

- Pick-A-Flow® airflow selector combined with SmartFlow™ technology simplifies the selection process and ensures optimum performance to meet code and reduce callbacks
- Built-in multi-speed control for ASHRAE 62.2 continuous ventilation compliance
- FV-0510VSCL1 features a built-in condensation sensor to control moisture in the bathroom
- UL approved for ceiling or wall mount – fits in a 2 x 4 stud wall
- Lighted model incorporates one 10W dimmable LED chip panel with <1W LED night light for warm, long-life energy efficient illumination (night light must be wired separately)
- Unique L-shaped bracket simplifies installation and provides strong support
- Wall installation reduces cost by eliminating the need to incorporate a radiation damper when penetrating fire rated ceilings, making it ideal for multi-family applications
- Complies with ASHRAE 62.2, Indoor airPlus, JA8 compliant for CA Title 24 and CALGreen4



Pick-A-Flow® Airflow Selector Switch



Optional 4" Oval to 3" Round Duct Adapter (Model #: FV-VS43R)



Optional Transfer Register Box (Model #FV-JD)



**LED Lighting**

INCLUDES: 10W Dimmable LED chip panel with <1W LED night light for warm, energy efficient illumination. Panel specifications include: 3000 Kelvin Warm White/90CRI/700 lumens/70 LPW/JA8 compliant for CA Title 24/50,000 hours rated average life.

WhisperValue DC Characteristics	FV-0810VSSL1 (Fan/Light)																	
	4" Oval Duct			4" Oval Duct			4" Oval Duct			4" Oval Duct			4" Oval Duct			4" Oval Duct		
Static pressure in inches w.g.	0.1	0.25	0.375	0.1	0.25	0.375	0.1	0.25	0.375	0.1	0.25	0.375	0.1	0.25	0.375	0.1	0.25	0.375
Air Volume (CFM)	100	101	83	80	81	75	70	72	70	60	64	65	50	52	52	40	41	42
Noise (sones)	0.9	1.3	-	0.4	0.8	-	<0.3	0.6	-	<0.3	0.6	-	<0.3	0.4	-	<0.3	0.5	-
Power Consumption (Watts)	13.4	18.5	18.0	8.5	13.2	16.0	6.5	10.8	15.0	5.3	9.3	13.0	4.5	7.7	12.0	3.8	6.7	10.0
Energy Efficiency (CFMs/Watt)	7.5	5.5	4.6	10.0	6.5	4.7	11.2	6.9	4.7	11.8	7.2	5.0	12.1	7.3	4.3	11.8	6.9	4.2
Speed (RPM)	970	1197	1300	856	1114	1270	805	1088	1260	770	1076	1250	733	1050	1230	723	1037	1215
Amps (Current)	0.22	0.29	0.25	0.13	0.20	0.24	0.10	0.16	0.22	0.09	0.15	0.20	0.08	0.13	0.17	0.07	0.11	0.15
Power Rating (V/Hz)	120/60			120/60			120/60			120/60			120/60			120/60		

WhisperValue DC Characteristics	FV-0510VSL1 (Fan/Light)								
	4" Oval Duct			4" Oval Duct			4" Oval Duct		
Static pressure in inches w.g.	0.1	0.25	0.375	0.1	0.25	0.375	0.1	0.25	0.375
Air Volume (CFM)	100	101	83	80	81	75	50	52	52
Noise (sones)	0.9	1.3	-	0.4	0.8	-	<0.3	0.4	-
Power Consumption (Watts)	13.4	18.5	18.0	8.5	13.2	16.0	4.5	7.7	12.0
Energy Efficiency (CFMs/Watt)	7.5	5.5	4.6	10.0	6.5	4.7	12.1	7.3	4.3
Speed (RPM)	970	1197	1300	856	1114	1270	733	1050	1230
Amps (Current)	0.22	0.29	0.25	0.13	0.20	0.24	0.08	0.13	0.17
Power Rating (V/Hz)	120/60			120/60			120/60		

WhisperValue DC Characteristics	FV-0510VSCL1 (Fan/Light)								
	4" Oval Duct			4" Oval Duct			4" Oval Duct		
Static pressure in inches w.g.	0.1	0.25	0.375	0.1	0.25	0.375	0.1	0.25	0.375
Air Volume (CFM)	100	101	83	80	81	75	50	52	52
Noise (sones)	0.9	1.3	-	0.4	0.8	-	<0.3	0.4	-
Power Consumption (Watts)	13.4	18.5	18.0	8.5	13.2	16.0	4.5	7.7	12.0
Energy Efficiency (CFMs/Watt)	7.5	5.5	4.6	10.0	6.5	4.7	12.1	7.3	4.3
Speed (RPM)	970	1197	1300	856	1114	1270	733	1050	1230
Amps (Current)	0.22	0.29	0.25	0.13	0.20	0.24	0.08	0.13	0.17
Power Rating (V/Hz)	120/60			120/60			120/60		

**SWDGET**

**SUGGESTED PRODUCTS**



On-Off Switch S16001WA



Temperature, Humidity & Motion Sensor W1006UWA



20/40/60 Control Switch S16008WA



Temperature, Humidity & Motion Sensor W1006UWA



**FV-0511VH1** 50-80-110 CFM 4" Duct  
**FV-0511VHL1** 50-80-110 CFM 4" Duct



7-3/4" Depth



**KEY FEATURES**

- Precision spot ventilation fan/heater combo pairs a powerful ECM motor with SmartFlow™ technology for optimum airflow and CFM output
- Built-in 1600W positive temperature coefficient heater delivers instant warm-up for ultimate comfort and Panasonic's legendary long-life operation
- Unique, adjustable grille with built-in diffuser offers superior directional heating
- Pick-A-Flow® and SmartFlow™ work together to assure required airflow (50-80-110 CFM), optimal exhaust power, code compliance and reduced callbacks
- Lighted model (FV-0511VHL1) incorporates one 10W dimmable LED chip panel with <1W LED night light for warm, long-life energy efficient illumination (night light must be wired separately)
- Flex-Z Fast® bracket enables fast, flexible room side installation
- Complies with ASHRAE 62.2



**LED Lighting:**

Includes: 10 Watt dimmable LED chip panel/3000 Kelvin Warm White/≥90CRI/750 lumens/≥70 LPW/JA-8 compliant for CA Title 24/50,000 hours rated average life /<1W LED night light included.

Specifications	WhisperWarm® DC (Fan/Heater)									WhisperWarm® DC (Fan/Heater/Light)								
	FV-0511VH1									FV-0511VHL1								
	4"			4"			4"			4"			4"			4"		
Static Pressure in inches w.g.	0.1	0.25	0.375	0.1	0.25	0.375	0.1	0.25	0.375	0.1	0.25	0.375	0.1	0.25	0.375	0.1	0.25	0.375
Air Volume (CFM)	110	112	110	80	82	82	50	51	53	110	111	99	80	81	82	50	52	53
Noise (sones)	0.7	1.5	-	<0.3	1.0	-	<0.3	0.8	-	0.7	1.5	-	<0.3	1.0	-	<0.3	0.7	-
Power Consumption (watts)	12	19.0	26.0	7.7	13.3	18.2	4.7	8.6	12.3	12.4	19.8	26.0	7.4	13.1	18.6	4.7	8.9	12.7
Energy Efficiency (CFM/Watt)	9.2	5.9	4	10.4	6.2	4.5	10.6	5.9	4.3	8.9	5.6	3.8	10.8	6.2	4.4	10.6	5.9	4.2
Speed (RPM)	861	1090	1249	736	1008	1173	638	930	1112	885	1115	1265	745	1022	1194	654	943	1130
Current (amps)	0.24	0.37	0.49	0.16	0.26	0.35	0.10	0.18	0.25	0.25	0.39	0.48	0.15	0.27	0.37	0.10	0.18	0.26
MAX. Current (amps)	0.50									0.50								
Power Rating (V/Hz)	120/60									120/60								

**Single Pack**

FV - 0709VB1: Fan Housing with Motor/Grille

**Contractor Pack**

FV-07VBA1A: Fan Housing  
FV-07VBB1: Motor/Grille Assembly



4-6/8" Depth

**KEY FEATURES**

- Ideal for new residential construction (high performance / ENERGY STAR® single family production builders and manufactured housing)
- The only 2-speed 70/90 CFM spot ventilation fan on the market (assures code compliance)
- The most cost effective 90 CFM, code compliant spot ventilation solution
- Delivers a true flow rating of 56 CFM at 0.375" static pressure (when set at the 90 CFM setting)
- Provides ventilation verification assurance: ≥50 CFM installed performance
- Junction box and duct adapter come pre-attached to the housing can
- Housing and motor / grille assembled and packed into a single package
- Housing and motor / grille packaged separately in contractor pack

EcoVent						
SPECIFICATIONS	FV - 0709VB1 / FV-07VBA1A+FV-07VBB1					
Characteristics (HVI tested data for 0.1" S.P.)	Standard Speed			High Speed		
Static Pressure in inches w.g.	0.1	0.25	0.375	0.1	0.25	0.375*
Air Volume (CFM)	70	56	34	90	75	56
Noise (sones)	0.7	1.3	-	1.5	1.5	-
Power Consumption (watts)	17.8	17.2	-	22.0	21.4	-
Energy Efficiency (CFM/Watt)	3.5	2.8	1.7	3.8	3.1	2.3
Speed (RPM)	907	1200	1425	1019	1266	1450
Current (amps)	0.15	0.14	0.15	0.19	0.18	0.17
MAX. Current(amps)	0.25					
Power Rating (V/Hz)	120/60					



Two Speed Fan Switch (70/90 CFM)

**ECOVENT SINGLE PACKAGE**

Model #	Description	Contents	Master Pack
FV-0709VB1	Fully Assembled into one box	Housing Can, Duct Adapter, Junction Box, Motor & Grille	1

**OPTIONAL ECOVENT UNIVERSAL CAN CONTRACTOR PACKS**

Model #	Description	Contents	Master Pack*
FV-07VBA1A	Universal Housing Can	Housing Can, Duct Adapter & Junction Box	4
FV-07VBB1	Motor/Grille Assembly	Motor & Grille	4

\*Must order in quantities of 4, shipment will contain 1 box with 4 pieces of each item.



**SUGGESTED PRODUCTS**



**On-Off Switch**  
S16001WA

**Motion Sensor**  
W1004UWA



Scan code to view EcoVent installation

FV-15NLF51H  
50-60-70-80-90-100-110-130-150 CFM 6" Duct



**KEY FEATURES**

- Upgraded Junction box on hardwired models has 2 convenient knockouts for routing power
- Customizable fresh air supply fan featuring Pick-A-Flow® technology – one fan, you select from 9 CFM levels - 50, 60, 70, 80, 90, 100, 110, 130, 150
- Intelligent ECM motor with SmartFlow™ technology provides optimum CFM output for precision whole-house supply ventilation
- Operates as a stand-alone filtered supply fresh air solution to meet ASHRAE 62.2 requirements for make-up / supply air
- Capable of communicating with Panasonic's acclaimed WhisperGreen® Select to create a balanced ventilation solution
- Incorporates adjustable high humidity and low temperature dials for easy adjustments in any climate zone
- Pressure ports for airflow verification
- Built-in Plug'n play module port with smart home capability
- HVI tested and certified with a MERV 13 filter (FV-FL1315NL1) Optional MERV 8 filters also available
- Complies with ASHRAE 62.2, LEED, CA Title 24 and HVI certified



**CFM**  
Select from 50/60/70/80/90/100/110/130/150 CFM [9 settings].



**Humidity Setting**  
Customizable fresh air supply based on humidity conditions of incoming air.



**Temperature Setting**  
Customizable low temperature setting will shut fan off when incoming supply air is too cold.



**Reset Button**  
Resets every time customer changes filter.



**Wi-Fi Module**  
(WP100PBA)

**Accessories (Sold Separately):**



**FV-FL0815NL1** MERV 8 Replacement Filter



**FV-FL1315NL1** MERV 13 Replacement Filter

WhisperFresh Select	FV-15NLF51H																								
Characteristics																									
Static pressure in inches w.g.	0.2	0.3	0.4	0.2	0.3	0.4	0.2	0.3	0.4	0.2	0.3	0.4	0.2	0.3	0.4	0.2	0.3	0.4	0.2	0.3	0.4	0.2	0.3	0.4	
Air Volume (CFM)	150	150	130	140	140	130	130	129	130	120	118	116	110	110	109	100	100	100	90	88	90	80	80	80	
Power Consumption (Watts)	27.3	32.0	-	24.8	29.0	-	22.6	25.0	-	19.4	23.0	-	16.7	20.0	-	15.3	18.0	21.0	13.5	15.0	19.0	12.4	14.0	17.0	
Energy Efficiency (CFMs/Watt)	5.59	4.68	-	5.97	4.82	-	6.30	5.20	-	6.72	5.21	-	7.05	5.50	-	7.45	5.55	4.76	7.61	6.00	4.73	7.83	5.71	4.70	
Speed	1314	-	-	1265	-	-	1235	-	-	1201	-	-	1152	-	-	1121	-	-	1086	-	-	1067	-	-	1033
Current	0.41	0.46	-	0.26	0.42	-	0.33	0.38	-	0.29	0.34	-	0.25	0.31	-	0.23	0.28	0.32	0.20	0.25	0.29	0.18	0.22	0.26	
Power Rating (V/Hz)	120/60																								



**SWDGET**

**SUGGESTED PRODUCTS**



**On-Off Switch**  
S16001WA



**Wi-Fi Control**  
W1000UWA



# Energy Recovery Ventilators (ERV)



Balanced ventilation for any project that you desire



BalancedHome™



Intelli-Balance®  
100



WhisperComfort®  
60



Intelli-Balance®  
200

**BalancedHome Elite Plus+ Models**  
**FV-16VEC1T – Top Port (30-160 CFM)**  
**FV-16VEC1S – Side Port (30-160 CFM)**  
**FV-13VEC1T – Top Port (30-130 CFM)**  
**FV-13VEC1S – Side Port (30-130 CFM)**



BalancedHome Elite Plus+  
FV-16VEC1T – Top Port



BalancedHome Elite Plus+  
FV-16VEC1S – Side Port

### KEY FEATURES

- Top rated sensible recovery efficiency of 82% complies with IECC code requirements.
- Automatic frost prevention mode to stop core from freezing in extreme temperatures
- Equipped with state-of-the-art Smartflow technology to provide balanced ventilation
- Vertical and horizontal port configuration options to fit your installation need
- Feature rich controls enable the HVAC professional to customize to the homeowner's specification.
- Advanced MERV 13 filter included; Optional MERV 8 and washable MERV 6 filters are also available
- Integrated optional touch screen LED wall control allows for CFM selection, occupant controllable boost function, and status / error updates
- Compatible for all climate zones
- All models are equipped with a standard power cord and include an optional hardwire adaptor in the box
- Active fault indicator alerts to notify user when maintenance is required
- Complies with ENERGY STAR®, ASHRAE 62.2, Indoor airPlus, California Title-24, and Washington State Residential Energy Code
- Wi-Fi Module - Responds automatically to poor air conditions. Communicates with other ventilation devices, including supply fans and energy recovery ventilators, to manage indoor air quality more efficiently.



### OPTIONAL TOUCH SCREEN LED Wall Control (FV-SC16VEC1)

The all new touchscreen LED wall control (sold separately) allows for total control of the unit. The wall control provides the user access to multiple ventilation control settings along with updates for real-time air flow, fault indicator display and temperature monitoring.



Wi-Fi Module  
(WP100PBA)

FV-16VEC1T												
Energy Performance												
Mode	Outdoor Temperature		Net Air Flow		Power consumed [Watt]	Sensible Recovery Efficiency	Adjusted Sensible Recovery Efficiency	Latent Recovery / Moisture Transfer	Apparent Sensible Effectiveness <sup>1</sup>	Total Recovery Efficiency	Adjusted Total Recovery Efficiency	CFM/W
	°C	°F	L/S	CFM								
Heating	0	32	17	36	25	82	84	0.81	89	-	-	1.4
	0	32	31	66	44	79	81	0.74	84	-	-	1.5
	0	32	61	129	109	73	75	0.64	78	-	-	1.1
-25°C	-25	-13	24	51	118	65	70	0.63	91	-	-	0.4
	-25	-13	31	66	163	60	65	0.60	87	-	-	0.4
Cooling	35	95	17	36	26	-	-	0.80	81	73	75	1.3
	35	95	31	66	48	-	-	0.70	76	68	70	1.3
	35	95	57	121	110	-	-	0.60	66	61	63	1.1

FV-16VEC1S												
Energy Performance												
Mode	Outdoor Temperature		Net Air Flow		Power consumed [Watt]	Sensible Recovery Efficiency	Adjusted Sensible Recovery Efficiency	Latent Recovery / Moisture Transfer	Apparent Sensible Effectiveness <sup>1</sup>	Total Recovery Efficiency	Adjusted Total Recovery Efficiency	CFM/W
	°C	°F	L/S	CFM								
Heating	0	32	17	36	25	82	84	0.81	89	-	-	1.4
	0	32	31	66	44	79	81	0.74	84	-	-	1.5
	0	32	61	129	109	73	75	0.64	78	-	-	1.1
-25°C	-25	-13	24	51	118	65	70	0.63	91	-	-	0.4
	-25	-13	31	66	163	60	65	0.60	87	-	-	0.4
Cooling	35	95	17	36	26	-	-	0.80	81	73	75	1.3
	35	95	31	66	48	-	-	0.70	76	68	70	1.3
	35	95	57	121	110	-	-	0.60	66	61	63	1.1

FV-13VEC1T												
Energy Performance												
Mode	Outdoor Temperature		Net Air Flow		Power consumed [Watt]	Sensible Recovery Efficiency	Adjusted Sensible Recovery Efficiency	Latent Recovery / Moisture Transfer	Apparent Sensible Effectiveness <sup>1</sup>	Total Recovery Efficiency	Adjusted Total Recovery Efficiency	CFM/W
	°C	°F	L/S	CFM								
Heating	0	32	17	36	26	81	83	0.80	88	-	-	1.3
	0	32	31	66	48	78	80	0.73	83	-	-	1.3
	0	32	59	125	109	73	75	0.63	77	-	-	1.1
-25°C	-25	-13	24	51	118	65	70	0.63	91	-	-	0.4
	-25	-13	31	66	163	60	65	0.60	87	-	-	0.4
Cooling	35	95	17	36	27	-	-	0.79	80	71	73	1.3
	35	95	31	66	50	-	-	0.69	75	67	69	1.3
	35	95	57	121	112	-	-	0.59	65	58	60	1.0

FV-13VEC1S												
Energy Performance												
Mode	Outdoor Temperature		Net Air Flow		Power consumed [Watt]	Sensible Recovery Efficiency	Adjusted Sensible Recovery Efficiency	Latent Recovery / Moisture Transfer	Apparent Sensible Effectiveness <sup>1</sup>	Total Recovery Efficiency	Adjusted Total Recovery Efficiency	CFM/W
	°C	°F	L/S	CFM								
Heating	0	32	17	36	26	81	83	0.80	88	-	-	1.3
	0	32	31	66	48	78	80	0.73	83	-	-	1.3
	0	32	59	125	109	73	75	0.63	77	-	-	1.1
-25°C	-25	-13	24	51	118	65	70	0.63	91	-	-	0.4
	-25	-13	31	66	163	60	65	0.60	87	-	-	0.4
Cooling	35	95	17	36	27	-	-	0.79	80	71	73	1.3
	35	95	31	66	50	-	-	0.69	75	67	69	1.3
	35	95	57	121	112	-	-	0.59	65	58	60	1.0



\*This product meets strict energy efficiency guidelines set by Natural Resources Canada and is ENERGY STAR® certified for the Canadian market only. There are no current Energy Star ratings for Energy Recovery Ventilators in the US market.

**BalancedHome Elite Models**  
**FV-15VE1T – Top Port (30-150 CFM)**  
**FV-15VE1S – Side Port (30-150 CFM)**  
**FV-12VE1T – Top Port (30-120 CFM)**  
**FV-12VE1S – Side Port (30-120 CFM)**



BalancedHome Elite  
 FV-15VE1T – Top Port



BalancedHome Elite  
 FV-15VE1S – Side Port

### KEY FEATURES

- Equipped with state-of-the-art Smartflow technology to provide balanced ventilation
- Vertical or horizontal port configuration options to fit your installation needs
- Feature rich controls enable the HVAC professional to customize to the homeowner's specification.
- Advanced MERV 8 filter included; Optional MERV 13 and washable MERV 6 filters are also available
- Integrated optional touch screen LED wall control allows for CFM selection, occupant controllable boost function, and status / error updates
- All models are equipped with a standard power cord and include an optional hardwire adaptor in the box
- Active fault indicator alerts to notify user when maintenance is required
- Complies with ASHRAE 62.2, Indoor airPlus, California Title-24, and Washington State Residential Energy Code
- Wi-Fi Module - Responds automatically to poor air conditions. Communicates with other ventilation devices, including supply fans and energy recovery ventilators, to manage indoor air quality more efficiently.



### OPTIONAL TOUCH SCREEN LED Wall Control (FV-SC16VEC1)

The all new touchscreen LED wall control (sold separately) allows for total control of the unit. The wall control provides the user access to multiple ventilation control settings along with updates for real-time air flow, fault indicator display and temperature monitoring.



Wi-Fi Module  
 (WP100PBA)

FV-15VE1T												
Energy Performance												
Mode	Outdoor Temperature		Net Air Flow		Power consumed [Watt]	Sensible Recovery Efficiency	Adjusted Sensible Recovery Efficiency	Latent Recovery / Moisture Transfer	Apparent Sensible Effectiveness <sup>1</sup>	Total Recovery Efficiency	Adjusted Total Recovery Efficiency	CFM/W
	°C	°F	L/S	CFM								
Heating	0	32	17	36	20	77	79	0.67	86	-	-	1.80
	0	32	31	66	33	73	75	0.58	79	-	-	2.00
	0	32	71	150	98	64	66	0.50	69	-	-	1.53
Cooling	35	95	17	36	23	-	-	0.78	77	70	72	1.56
	35	95	31	66	37	-	-	0.66	70	64	66	1.78
	35	95	57	121	102	-	-	0.56	58	53	55	1.18

FV-15VE1S												
Energy Performance												
Mode	Outdoor Temperature		Net Air Flow		Power consumed [Watt]	Sensible Recovery Efficiency	Adjusted Sensible Recovery Efficiency	Latent Recovery / Moisture Transfer	Apparent Sensible Effectiveness <sup>1</sup>	Total Recovery Efficiency	Adjusted Total Recovery Efficiency	CFM/W
	°C	°F	L/S	CFM								
Heating	0	32	17	36	20	77	79	0.67	86	-	-	1.80
	0	32	31	66	33	73	75	0.58	79	-	-	2.00
	0	32	71	150	98	64	66	0.50	69	-	-	1.53
Cooling	35	95	17	36	23	-	-	0.78	77	70	72	1.56
	35	95	31	66	37	-	-	0.66	70	64	66	1.78
	35	95	57	121	102	-	-	0.56	58	53	55	1.18

FV-12VE1T												
Energy Performance												
Mode	Outdoor Temperature		Net Air Flow		Power consumed [Watt]	Sensible Recovery Efficiency	Adjusted Sensible Recovery Efficiency	Latent Recovery / Moisture Transfer	Apparent Sensible Effectiveness <sup>1</sup>	Total Recovery Efficiency	Adjusted Total Recovery Efficiency	CFM/W
	°C	°F	L/S	CFM								
Heating	0	32	17	36	22	76	78	0.66	85	-	-	1.63
	0	32	31	66	35	72	74	0.57	78	-	-	1.88
	0	32	57	121	73	65	67	0.49	70	-	-	1.65
Cooling	35	95	17	36	24	-	-	0.77	76	68	70	1.50
	35	95	31	66	39	-	-	0.65	69	61	63	1.69
	35	95	52	110	77	-	-	0.56	59	53	55	1.42

FV-12VE1S												
Energy Performance												
Mode	Outdoor Temperature		Net Air Flow		Power consumed [Watt]	Sensible Recovery Efficiency	Adjusted Sensible Recovery Efficiency	Latent Recovery / Moisture Transfer	Apparent Sensible Effectiveness <sup>1</sup>	Total Recovery Efficiency	Adjusted Total Recovery Efficiency	CFM/W
	°C	°F	L/S	CFM								
Heating	0	32	17	36	22	76	78	0.66	85	-	-	1.63
	0	32	31	66	35	72	74	0.57	78	-	-	1.88
	0	32	57	121	73	65	67	0.49	70	-	-	1.65
Cooling	35	95	17	36	24	-	-	0.77	76	68	70	1.50
	35	95	31	66	39	-	-	0.65	69	61	63	1.69
	35	95	52	110	77	-	-	0.56	59	53	55	1.42

**Hardwired Models:**

- FV-10VEC2RH (Any Climate Mirror Model)
- FV-10VEC2H (Any Climate)
- FV-10VE2H (Temperate Climate)

**Standard Plug in Models:**

- FV-10VEC2R (Any Climate Mirror Model)
- FV-10VEC2 (Any Climate)
- FV-10VE2 (Temperate Climate)



Control Terminals

**KEY FEATURES**

- FV-10VE2H; FV-VEC2H; FV-10VEC2RH Hardwired models to complement the Intelli-Balance product portfolio, where direct wired power is required.
- Junction box on hardwired models has 2 convenient knockouts for routing power.
- FV-10VEC2R model to complete the series with a single family residential or multi-family residential application that requires a mirrored (reverse) model.
- Occupant controllable boost function. Moves fan speed to high when activated.
- Designed for multi-family dwellings and new homes built to meet energy efficiency standards.
- FV-10VEC2; FV-10VEC2R; and FV-10VEC2RH models are engineered for use in any North America climate zone; meets Ontario, ENERGY STAR® and Novoclima requirements<sup>3</sup>
- Two (2) powerful ECM motors with Smart Flow™ technology ensure optimum airflow by overcoming static pressure to effectively remove contaminated air and replace it with fresh air.
- Multi-speed selector (30 to 100 CFM) provides customizable airflow to create balanced, positive or negative pressure within the residential and commercial spaces.
- Highest energy recovery efficiency performer in the 150 CFM and under ERV class.
- Core material permeated with anti-mold treatment to help prevent mold.
- Built-in ASHRAE 62.2 timing function helps ensure code compliance and simplifies the installation process.
- MERV 8 filter included; Optional MERV 13 filters are also available
- Connect to existing ductwork or use as a standalone, whole-house ventilation solution.
- Can be used to meet Green Building Code requirements and contribute to better HERS/ERI scores.

**Built-In Controls**

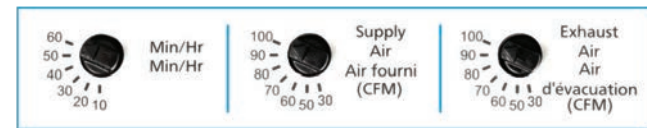

ASHRAE 62.2 Timer

Multi-Speed Supply

Multi-Speed Exhaust

**Accessories (Sold Separately)**



FV-FL0810VE1 MERV 8 Replacement Filter  
FV-FL1310VE1 MERV 13 Replacement Filter



FV-WC10VE1\* WhisperVent Wall Cap  
\*FV-WC10VE1 is ideal for use in smaller, multi-family applications. Can be used at CFM settings up to 100 CFM.



Enthalpic Transfer Core



Return Air Filter

Intelli-Balance 100	
Characteristics	
Static pressure in inches w.g.	0.1 0.4
Gross Exhaust Air Volume [CFM]	100 100
Net Supply Air Volume [CFM]	100 100
Power Consumption [Watts]	81 90
Power Rating [V/Hz]	120/60
ENERGY STAR® Certified	FV-10VEC2, FV-10VEC2R, FV-10VEC2RH

**FV-10VEC2RH/FV-10VEC2R/FV-VEC2H/FV-10VEC2**

Supply Temperature		Net Air Flow		Power Consumed [Watts]	Sensible Recovery Efficiency	Apparent Sensible Recovery Efficiency	Net Moisture Transfer
°C	°F	L/S	CFM				
Heating							
0	32	25	53	29	80	83	0.78
0	32	31	66	39	77	81	0.74
0	32	40	85	68	73	77	0.71
-25	-13	27	57	77	65	67	0.71
-25	-13	30	64	100	56	60	0.58
Cooling							
35	95	23	49	32	Total Recovery Efficiency		60

**FV-10VE2H/FV-10VE2**

Supply Temperature		Net Air Flow		Power Consumed [Watts]	Sensible Recovery Efficiency	Apparent Sensible Recovery Efficiency	Net Moisture Transfer
°C	°F	L/S	CFM				
Heating							
0	32	25	53	29	80	83	0.78
0	32	31	66	39	77	81	0.74
0	32	40	85	68	73	77	0.71
Cooling							
35	95	23	49	32	Total Recovery Efficiency		60

**Intelli-Balance 100 Dimensions**

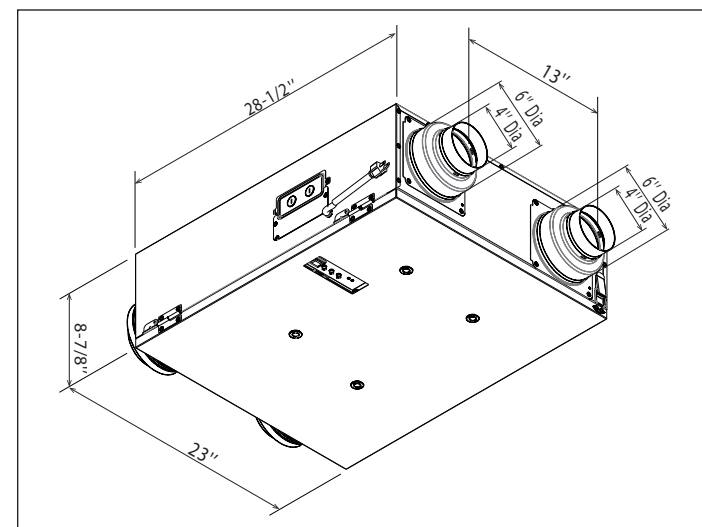

**SWDGET**

**SUGGESTED PRODUCTS**

Intelli-Balance 100 - Boost Function

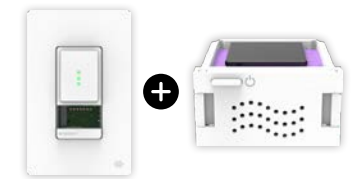

20/40/60 Control Switch S16008WA

IAQ Sensor W1008UWA

Intelli-Balance 100 - On/Off

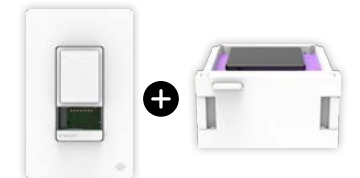

Auxiliary Control Switch S16009WA

Wifi Control W1000UWA

<sup>1</sup> Highest CFM rating for supply and exhaust at 0.4 static pressure

<sup>2</sup> This product meets strict energy efficiency guidelines set by Natural Resources Canada and is ENERGY STAR® certified for the Canadian market only. There are no current Energy Star ratings for Energy Recovery Ventilators in the US market.

<sup>3</sup> Meets established energy efficiency standards in Canada for climate Zone 1 - fewer than 6,000 heating degree days (HDD)

FV-20VEC1  
60 to 200 CFM



LCD Wall Control Panel FV-SW20VEC1 (Sold Separately)

KEY FEATURES

- Multi-speed selector (60 to 200CFM) provides customizable supply and exhaust airflow to create balanced, positive or negative pressure within a residential or commercial space
- Two (2) powerful ECM motors with Smart Flow™ technology ensure predictable airflow outputs up to .40" w.g. of static pressure
- Occupant controllable boost function provides increased ventilation on demand
- Designed for single family dwellings and new airtight envelopes built to meet energy efficiency standards
- Engineered for use in any North America climate zone<sup>1</sup>
- Powder coat finish with core material permeated with anti-mold treatment
- Built-in ASHRAE 62.2 intermittent timing function helps ensure code compliance and simplifies the installation process
- MERV 13 filter included for superior air filtration; MERV 8 and HEPA filters also available
- Connect to existing ductwork or use as a standalone, whole-house ventilation solution
- Can be used to meet Green Building Standards and contribute to better HERS/ERI scores

Intelli-Balance <sup>®</sup> 200	FV-20VEC1
<b>Characteristics</b>	COLD/TEMPERATE CLIMATE
Static pressure in inches w.g.	0.4
Net Exhaust Air Volume (CFM)	200
Net Supply Air Volume (CFM)	200
Power Consumption (Watts)	129
Power Rating (V/Hz)	120/60
ENERGY STAR <sup>®</sup> Certified	Yes <sup>1</sup>

Energy Performance								
MODE	Supply Temperature		Net Air Flow		Power Consumed (Watts)	Sensible Recovery Efficiency	Apparent Sensible Effectiveness	Net Moisture Transfer
	°F	°C	L/S	CFM				
Heating	32	0	32	67	22	83%	86%	81%
	32	0	59	124	46	77%	79%	73%
	32	0	80	170	92	73%	77%	78%
	-13	-25	31	66	46	67%	69%	70%
	-13	-25	50	107	104	61%	64%	64%
Cooling	Total Recovery Efficiency							
	95	35	34	71	25	70%		
	95	35	64	135	56	61%		

Intelli-Balance Accessory Kits						
Model No.	Description	Inlet Grille	Backdraft Damper	Clamp	Y-Adapter	
FV-NLF04G	4" Inlet Grille + Metal Plate	1 (4")	-	-	-	
FV-NLF06G	6" Inlet Grille + Metal Plate	1 (6")	-	-	-	
PC-NLF04S	4" Single Inlet Kit	1 (4")	1 (4")	6	-	
PC-NLF06S	6" Single Inlet Kit	1 (6")	1 (6")	6	-	
PC-NLF04D	4" Double Inlet Kit	2 (4")	2 (4")	12	1 (4" - 4" x 2)	
PC-NLF06D	6" Double Inlet Kit	2 (6")	2 (6")	12	1 (6" - 6" x 2)	
PC-NLF64D	6" - 4" Double Inlet Kit	2 (4")	2 (4")	12	1 (6" - 4" x 2)	
PC-NLF86Y	8" - 6" Y-Adapter	-	-	-	1 (8" - 6" x 2)	
FV-NLF66RES	Recessed Inlet integrated dual 4" or 6" duct adaptor	-	-	-	-	

<sup>1</sup> This product meets strict energy efficiency guidelines set by Natural Resources Canada and is ENERGY STAR<sup>®</sup> certified for the Canadian market only. There are no current Energy Star ratings for Energy Recovery Ventilators in the US market.

FV-06VE1  
20-60 CFM



7-7/8" Depth

KEY FEATURES

- Sensible recovery efficiency of 70% at 32°F
- Total recovery efficiency of 60% at 95°F
- Multi-speed selector (20 to 50 CFM) provides customizable airflow
- Occupant controllable boost function moves fan speed to 60 CFM when activated
- Engineered for use in virtually any North America climate zone
- High efficiency capillary core recovers heat and helps maintain desired moisture levels inside
- Two (2) powerful DC Panasonic ECM motors provide quiet and efficient airflow
- MERV 13 replaceable filters for superior air filtration
- Core material permeated with anti-mold treatment to help prevent mold
- Separate control of supply and exhaust airflow
- (Optional) WhisperVent™ wall cap allows for supply and exhaust air through one building penetration - up to 100 CFM each side

Supply and exhaust air flows through a single exterior opening

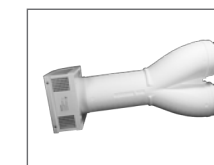
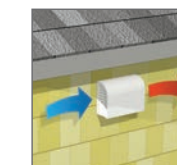

FV-WC10VE1  
WhisperVent Wall Cap

Performance Specifications: WhisperComfort <sup>®</sup> 60 FV-06VE1								
Mode	Supply Temperature		Net Air Flow		Power Consumption (w)	Sensible Recovery Efficiency	Apparent Sensible Recovery Efficiency	Net Moisture Transfer
	°F	°C	L/s	CFM				
Heating	32	0	9	20	9	70%	73%	0.7
	32	0	28	60	39	60%	63%	0.5
Cooling	Total Recovery Efficiency							
	95	35	13	27	12	70%		
	60%							

Sound Specifications: WhisperComfort <sup>®</sup> 60 FV-06VE1							
4" Duct	SP	CFM	Sones	CFM	Sones	CFM	Sones
	0.1"	60	2.5	50	1.5	40	0.9
0.25"	54	2.5	43	2.0	30	1.2	

SUGGESTED PRODUCTS

WhisperComfort 60 - Boost Function



20/40/60 Control Switch S16008WA  
IAQ Sensor W1008UWA

WhisperComfort 60 - On/Off



Auxiliary Control Switch S16009WA  
Wifi Control W1000UWA

SUGGESTED PRODUCTS

Intelli-Balance - Boost Function



20/40/60 Control Switch S16008WA  
IAQ Sensor W1008UWA

Intelli-Balance - On/Off



Auxiliary Control Switch S16009WA  
Wifi Control W1000UWA



Scan here for Intelli-Balance 200 video



### Controller, Supply Damper & FanConnect™ Wall Switch Kit SACG2K-04/06/08/10 4", 6", 8" or 10" Duct Options



#### KEY FEATURES

- Ideal for single and multi-family construction
- Provides whole house ventilation control that's integrated into the home's central HVAC system
- Durable, powered open/close damper alleviates damper chatter
- Controls WhisperGreen® Select and other ventilation fans to provide supplemental ventilation as needed to meet ASHRAE 62.2
- Two operational modes help a home achieve the lowest cost per HERS point for either supply or balanced ventilation strategies
- Works in tandem with spot exhaust fan to achieve hybrid supply or balanced ventilation
- Features a patented setup process, including two simple options: Flow vs Time
- Digital display panel shows system status and aids in troubleshooting
- Fan/light wall switch can be programmed from the controller to provide a delay timer function

SelectCycler® offers the **most cost effective** solution for meeting ventilation code and minimizing the impact to your HERS Index.

#### HERS Index Per Ventilation Design Strategy\*

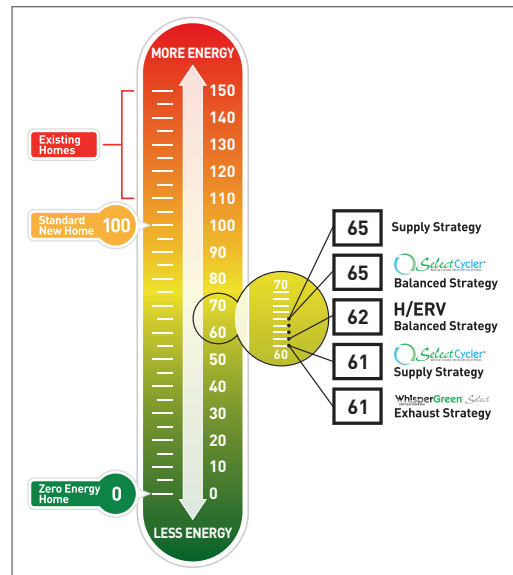

#### Ventilation Cost Per HERS Point Index\*



**WhisperGreen Select**  
ECM Motor and low watt consumption contribute to a low HERS Index Score and Cost Per HERS Point Index

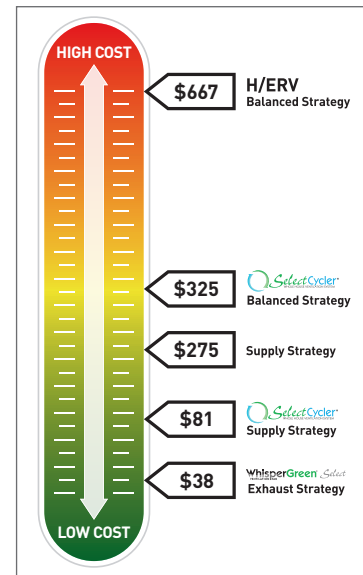

SelectCycler System **Balanced Mode** Lowest cost per HERS point for **Balanced Ventilation**

SelectCycler System **Hybrid Mode** Lowest cost per HERS point for **Supply Ventilation**

WhisperGreen® Select Lowest cost per HERS point for **Exhaust Ventilation**

\*Modeling conducted by third-party RESNET Provider EPX/NRGLogic

### SelectCycler Kit (SACG2K)



#### Programmable Wall Mounted Controller

- Ideal for single and multi-family construction
- Calculates supply duct and exhaust fan run cycles to meet ASHRAE 62.2
- Patented algorithm calculates operation time to meet ASHRAE 62.2 ventilation requirements
- Allows for programmable hours of operation



#### Motorized Supply Damper

- Stainless steel, power open/close damper
- Available in 4", 6", 8" or 10" duct size
- Operating voltage: 24VAC (up to 30VAC max)
- Current draw: 0.07 A idle; 0.125 A for 15 second damper transit time
- Damper can be installed in any position



#### FanConnect™ Bathroom Fan/Light Wall Switch

- Compatible with single, or multi-speed fans, set to a single speed setting
- Light: 450 Watts @ 120VAC (blue wire)
- Fan: 150 Watts @ 120VAC (red wire)
- Operation: 120VAC +/- 10%

#### Optional Accessories

Hot and cold temperature sensors disable the fresh air damper in extreme temperatures



- Hot Temperature Sensor (SACTG-H01)
- System control in extreme hot climates
  - OFF temperature: 95°F +/- 5°
  - ON temperature: 4°F lower
  - Operation: 2A @ 24VAC



- Cold Temperature Sensor (SACTG-C02)
- System control in extreme cold climates
  - OFF temperature: 35°F +/- 5°
  - ON temperature: 4°F higher
  - Operation: 2A @ 24VAC

# Atmosphere Dryer Exhaust Duct Ventilators



DBF-DEDPV



VTX-DEDPV

Panasonic provides the most powerful and enhanced products in our industry

Dryer Exhaust Solutions takes dryer ventilation to another level, while continuing our pledge to offer complete ventilation solutions, and healthier homes.



DBF-DEDPV



**Hard-wired, all in one product featuring an integrated lint trap and a pressure sensor to automatically sense when the dryer is on.**

**KEY FEATURES**

- Monitors internal pressure and notifies homeowner in case of a blockage
- Quick and easy maintenance cleaning
- Fast and easy wall mounted installation
- Galvanized steel housing ensuring long lasting rust protection
- Integrated lint trap with low pressure drop
- Reduces drying time and energy consumption
- Certified as a DEDPV UL705
- 10-year warranty

VTX-DEDPV



**UL705 rated exhaust fan that includes an integrated pressure sensor, and a wall-mounted indicator panel with 50ft of cable.**

**KEY FEATURES**

- Certified UL 705 dryer exhaust duct power ventilator suitable for gas & electric dryers
- Maintains minimum of 1,200 FPM air velocity
- LED indicator panel for operation status
- Reduce drying times and energy consumption
- Integrated high temperature thermal fuse for safety
- Complies with IRC Code
- Requires a lint trap

LT4 / LT4S



**Secondary Lint Trap that is installed between the dryer and dryer exhaust ventilator**

**KEY FEATURES**

- Powder coated 24Ga galvanized steel box with 4" adapters
- Fast and easy installation with finishing frame
- 4" window to monitor lint accumulation
- LT4 is equipped with a screen that filters the air that feeds into dryer exhaust fan
- LT4S is suitable in a 2" x 4" wall

SLT

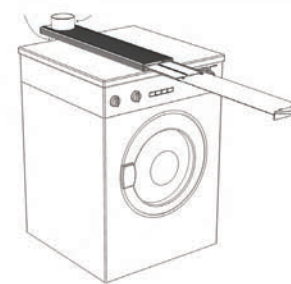

**Slim Lint Trap For Stackable Dryer Installation**

**KEY FEATURES**

- 41 sq. inch filtering area increases dryer efficiency
- Washable nylon filter screen
- 4" duct adapter
- Aluminum extrusion body and slider
- Simple and quick installation

## Atmosphere In-line Fans













Panasonic is a distributor of Atmosphere offering a suite of In-line fans and dryer exhaust duct power ventilators. All ventilators are best-in-category with a 10-year warranty for residential and light commercial applications.

## VTX Series High performance In-line duct blowers

### KEY FEATURES

- Suggested replacement for WhisperLine
- Aerodynamic design allowing more air flow
- Pre-wired with 120V power cord
- AMCA Air Listed



Style	Model Number	Features
	VTX400	Atmosphere Corded In-line Fan, 175 CFM at 0.2 s.p., for high static pressure applications and long duct runs, 4" duct, backdraft damper not included; speed controller available separately
	VTX400C	Atmosphere Corded In-line Fan with Integrated Current Sensor, 175 CFM at 0.2 s.p., for high static pressure applications and long duct runs, 4" duct, backdraft damper not included, speed controller available separately
	VTX400P	Atmosphere Corded Centrifugal In-line Fan with Integrated Pressure Switch, 175 CFM at 0.2 s.p., for high static pressure applications and long duct runs, 4" duct, backdraft damper not included, speed controller available separately
	VTX600L	Atmosphere Corded Centrifugal In-line Fan, 244 CFM at 0.2 s.p., for high static pressure applications and long duct runs, 6" duct, backdraft damper not included, speed controller available separately
	VTX600	Atmosphere Corded Centrifugal In-line Fan, 465 CFM at 0.2 s.p., for high static pressure applications and long duct runs, 6" duct, backdraft damper not included, speed controller available separately
	VTX800L	Atmosphere Corded Centrifugal In-line Fan, 602 CFM at 0.2 s.p., for high static pressure applications and long duct runs, 8" duct, backdraft damper not included, speed controller available separately

Style	Model Number	Features
	VTX800	Atmosphere Corded Centrifugal In-line Fan, 681 CFM at 0.2 s.p., for high static pressure applications and long duct runs, 8" duct, backdraft damper not included, speed controller available separately
	VTX1000	Atmosphere Corded Centrifugal In-line Fan, 723 CFM at 0.2 s.p., for high static pressure applications and long duct runs, 10" duct, backdraft damper not included, speed controller available separately
	VTX1200L	Atmosphere Corded centrifugal In-line Fan, 846 CFM at 0.2 s.p., for high static pressure applications and long duct runs, 12" duct, backdraft damper not included, speed controller available separately
	VTX1200	Atmosphere Corded Centrifugal In-line Fan, 1067 CFM at 0.2 s.p., for high static pressure applications and long duct runs, 12" duct, backdraft damper not included, speed controller available separately

## S-line Mixed Flow Fans designed for residential and light commercial ventilation applications

### KEY FEATURES

- Powerful, compact and quiet mixed flow impeller
- Easy to install - mounting brackets included
- 100% speed controllable
- Pre-wired with 120V power cord
- ETL & AMCA air listed
- 10-year warranty

Style	Model Number	Features
	S-600	Atmosphere Corded Mixed-Flow In-line Fan, 312 CFM at 0.2 s.p., 6" duct, sealed casing, compact design, backdraft damper included, speed controller available separately
	S-800	Atmosphere Corded Mixed-flow In-line Fan, 688 CFM at 0.2 s.p., 8" duct, sealed casing, compact design, backdraft damper included, speed controller available separately
	S-1000	Atmosphere Corded Mixed-Flow In-line Fan, 1032 CFM at 0.2 s.p., 10" duct, sealed casing, compact design, backdraft damper included, speed controller available separately

## Destratification Fans

- D-65 Black
- D-65 White



## 3D shaped fans powered by a mixed flow impeller

### KEY FEATURES

- Quiet, energy-efficient fans, delivering a focused, easy-to-direct column of air
- Run independently of existing HVAC system
- Effective in facilities with ceiling heights from 15' to 75' high
- Speed controllable, allowing fine-tuning for individual comfort
- 10-year limited warranty
- Destratification fans have a maximum 1082 CFM
- Includes 3 types of UL approved fast-mounting hardware
- Available in both white and black

## Accessories



### Dial-A-Temp DAT

#### KEY FEATURES

- Plug-in design - no tools required
- UL Listed
- Fire retardant thermoplastic enclosure
- On-Off switch, high to low variable
- 1-year Warranty
- Helps reduce fan or blower noise



### Solid State Variable Speed AC Motor Control AVR - 5 - 115

#### KEY FEATURES

- Fully Variable
- Rotary-style fan control
- Tough impact-resistant thermoplastic housing
- 1-year warranty
- Designed for mounting in a 2" X 4" electrical wall box



### Spring Loaded Backdraft Dampers BDD 4", 6", 8", 10", and 12"

#### KEY FEATURES

- All sizes include a metal sleeve
- Requires from 0.04" to 0.08" wg pressure to open
- Exterior foam gasket assures a tight seal against duct
- Gasket designed to withstand temperatures from -22° F to 180° F



## Empower your clients with Smart, Healthy Homes for good indoor air quality

Panasonic has created a simple yet robust ventilation strategy to help builders deliver healthy homes. Swidget smart controls and mobile app pair with Panasonic ventilation products to monitor, detect and auto-activate the proper fan when unhealthy air and moisture are detected. Removing harmful contaminants ensures homeowners breathe the highest quality air around the clock. Monitor. Detect. Auto-activate. It's that simple and that effective.

### Choose a Swidget sensor to monitor

-  Motion
-  Temperature
-  Humidity
-  Air Quality

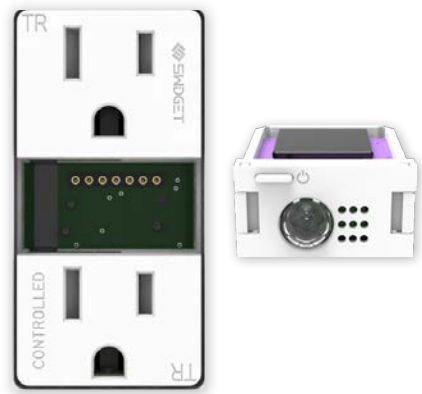

**KEY FEATURES**

- Breathe confidently with air that is always fresh.
- Empower Smart, Healthy Homes
- Smart Controls detect unhealthy air and automatically control Panasonic's ventilation products to remove unhealthy or contaminated air
- Pairing Swidget smart controls with Panasonic ventilation fans helps reduce harmful VOCs and allergens
- Variety of sensors that monitor motion, temperature, humidity and air quality

**Empower your home to ensure you are breathing clean, fresh air**

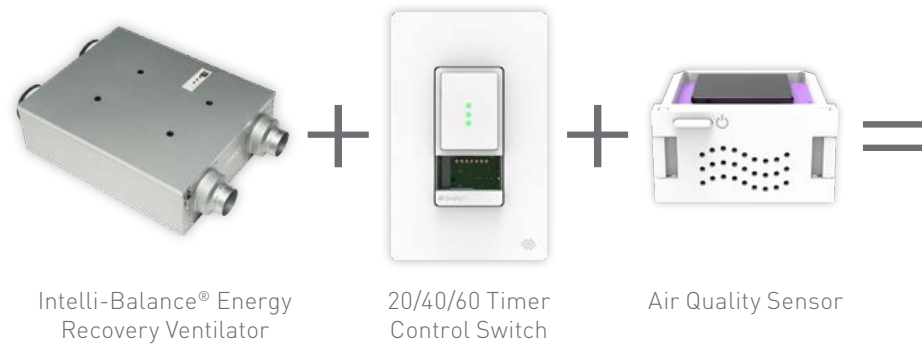

Swidget can monitor your indoor air quality and turn on your ERV when you need it most to keep your air clean and fresh.

**Empower your home to protect you from mold and mildew**

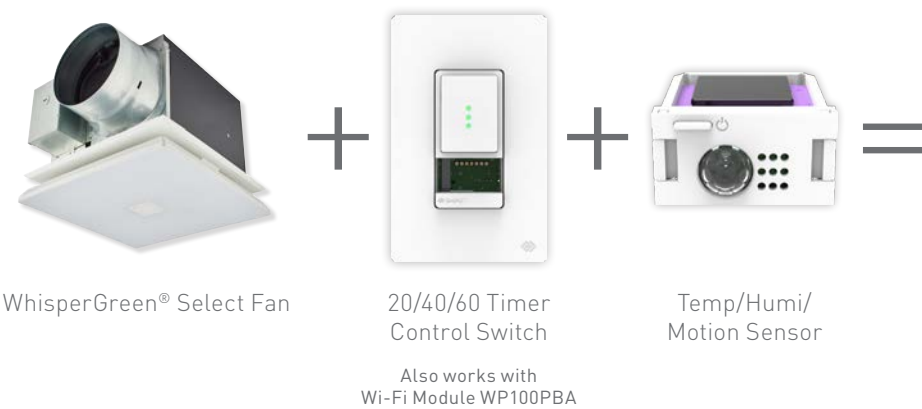

Set your fan to turn on automatically when Swidget detects the humidity levels are too high in your bathroom.

**WIRING DEVICES**



**INSERTS**

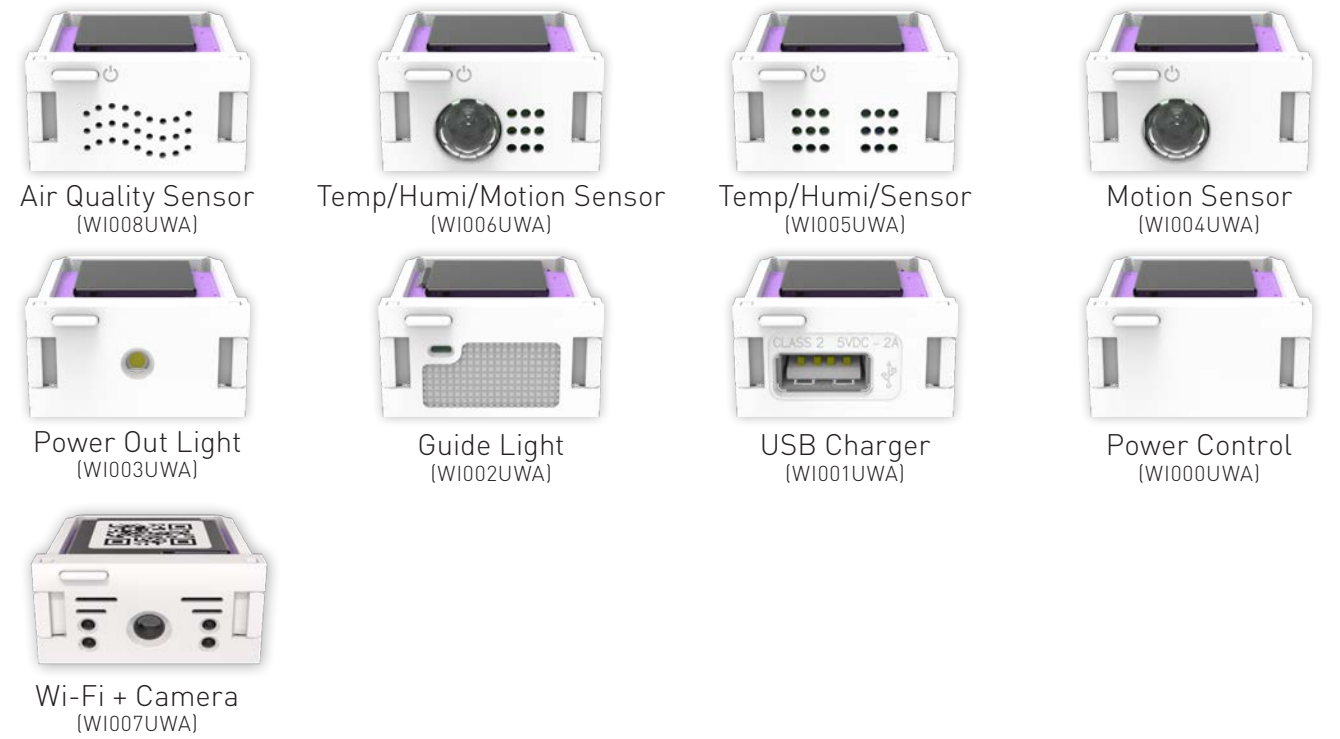

On/Off—  
**FV-WCCS1-W** (White),  
 On/Off/Light—  
**FV-WCCS2-W** (White),

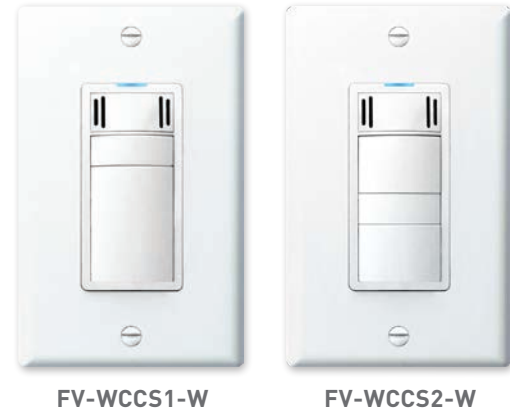

**KEY FEATURES**

- Intelligent and advanced sensor technology monitors humidity and temperature to anticipate dew point, automatically operating the fan to control moisture
- Automatic seasonal adaptability with optional Moisture Sensitivity Selector allows fine tuning for dry or moist environments
- Adjustable Minutes Per Hour (MPH) Fan Timer ensures consistent and controlled ventilation throughout the day for compliance with ASHRAE 62.2
- Automatic Fan Control – 30 minute countdown timer initiates after moisture returns to normal levels
- Manual Fan Control – 20 minute countdown timer initiates once fan is turned on
- Blue LED indicates when the fan is on
- Commercial Grade – 8 Amp max load, 2 year limited warranty
- Engineered to efficiently control current LED lighting and DC motor loads
- For indoor use. Includes matching wall plate
- Complies with ASHRAE 62.2, ENERGY STAR® 3.0 and CALGreen
- **One year additional fan warranty available when a Panasonic WhisperCeiling DC, WhisperValue DC or WhisperFit DC fan/light is controlled by a Panasonic Condensation Sensor Plus**

**Timer and Sensor Settings**

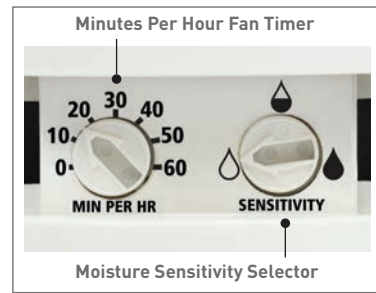

**Moisture Sensitivity Selector Settings**

- Low Sensitivity** – The least sensitive setting is used in hotter and more humid climates. In a very moist environment, low moisture sensitivity may be needed to avoid excessive fan run-time.
- Average Sensitivity** – The Condensation Sensor Plus comes factory set to this most common setting.
- High Sensitivity** – Setting the Condensation Sensor Plus to its most sensitive setting covers the widest range of humidity. This is a setting for dryer climates and/or larger rooms. In a very dry environment, higher sensitivity is needed.

WhisperControl Condensation Sensor Plus	FV-WCCS1-W	FV-WCCS2-W
Ground	Grounding	Grounding
Feature	Blue LED	Blue LED
Amperage	15 Amp	15 Amp
Maximum Fan Load	8 Amp	8 Amp
Voltage	120 Volts	120 Volts
Termination	6" Leads	6" Leads
Dry Contact Switching	24 Volt AC Input/Output	24 Volt AC Input/Output
Connections (Copper Wire Connections)	Use #14 or #12	Use #14 or #12
Max. Fluorescent Light Load	NA	400 Watt
Standard Certifications	UL/CSA Listed	UL/CSA Listed
Warranty	2 Year Limited	2 Year Limited

On/Off—  
**FV-WCD01-W** (White),  
 On/Off/Light—  
**FV-WCD02-W** (White),

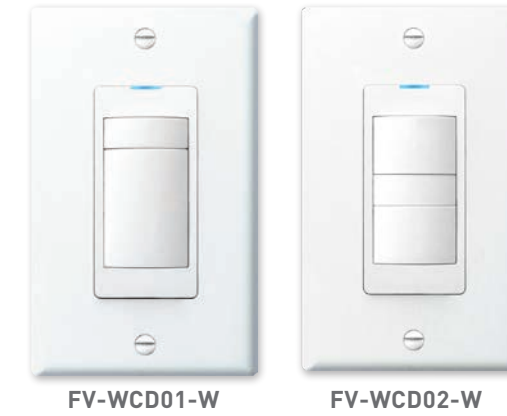

**KEY FEATURES**

- Preset the fan timer anywhere from 5–60 minutes
- Adjustable Minutes Per Hour (MPH) Fan Timer ensures consistent and controlled ventilation throughout the day
- Manual On/Off Fan Control
- Blue LED indicates when the fan is on
- Commercial Grade, 8 amp max load, 2-year limited warranty
- Engineered to efficiently control current LED lighting and DC motor loads
- For indoor use. Includes matching wall plate
- Complies with ASHRAE 62.2, and ENERGY STAR® 3.0

**Timer Settings**



Preset Countdown and Hourly Timer	FV-WCD01-W	FV-WCD02-W
Ground	Grounding	Grounding
Feature	Blue LED Light	Blue LED Light
Amperage	8 Amp	8 Amp
Dry Contact Switching	24V AC input/output	24V AC input/output
Max. Fluorescent Light Load	N/A	400 Watt
Termination	6" Leads	6" Leads
Standard Certifications	UL/CSA Listed	UL/CSA Listed
Warranty	2 Year Limited	2 Year Limited



**WhisperAir Repair**  
PURIFIED BY **nanoeX**

Ideal for hotel rooms and light commercial spaces

Whether updating old ventilation fans, remodeling entire spaces or building from the ground up, bolster your ventilation strategy with WhisperAir Repair<sup>®</sup> advanced spot air purifier by Panasonic. Featuring patented nanoe™X technology, WhisperAir Repair generates reactive molecules that help purify contaminated air while inhibiting odors, bacteria and viruses.\* Your customers will enjoy better indoor air quality and healthier living.



**EASY TO INSTALL**  
 Ceiling mount connects to existing wiring\*\*



**MAINTENANCE FREE, WORRY FREE**  
 No filters to change or duct work required

\*Tested with gram-positive bacteria (Staphylococcus epidermidis) showing a 97% reduction following continuous operation for 24 hours in a 1,728ft3 (49 m3) room. Data support a 99% reduction of the virus (Bacteriophage Ø X174) following continuous operation for 8 hours in 883ft3 (25 m3) room. Data supports a reduction of mold (Alternaria) following continuous operation for 8 hours in 812ft3 (23 m3) room.

\*\*Refer to local jurisdictions and manufacturer installation guide.

## Advanced Spot Air Purification and Odor Elimination



FV-01VCN1

### KEY FEATURES

- Quietly deodorizes and reduces unwanted smells for a fresher, cleaner indoor environment
- Ceiling mount spot purification device utilizes patented nanoe™ X charged water particle generation technology to purify contaminated air
- Inhibits growth of bacteria, viruses, allergens<sup>2</sup> and mold; and breaks down hazardous substances for a healthier<sup>1</sup> home environment<sup>1</sup>
- Maintenance free with no filters to change, no duct work required
- Great for use in residential settings including living rooms, bedrooms, basements, closets and mud rooms<sup>3</sup>
- Certified by Intertek for UL/CSA safety standards
- Complies with California Air Resources Board (CARB) for electrical safety and ozone requirements specified in Title 17, California Code of Regulations, subchapter 8.7 "Indoor Air Cleaning Devices."

Specifications	WhisperAir Repair®
	FV-01VCN1
Air Volume (CFM)	9
Noise (sones)	<0.3*
Power Consumption (watts)	4.0
Speed (RPM)	1510
Current (amps)	0.04
Power Rating (V/Hz)	120/60
Net Weight [Lb [kg]]	3.1 [1.4]



Our New Reality Means  
a New Standard

More time spent indoors makes **healthy homes** more important than ever.

Good indoor air quality (IAQ) is essential for healthy living. With an effective ventilation strategy that removes pollutants, moisture and germs while bringing in fresh air from outside, building healthier homes is easier than you think.

### PROPER VENTILATION — THE FOUNDATION OF A HEALTHY HOME



Indoor air quality is the #1 concern of homeowners when it comes to a healthy home.



Per the World Health Organization (WHO), increased ventilation rates can reduce virus and bacteria counts in the air, along with the infection rates of airborne diseases.



Common indoor toxins such as carbon dioxide, particulate matter and volatile organic compounds have been linked to respiratory and other health problems.

Panasonic is helping builders across the country differentiate themselves with powerful, code compliant indoor air quality solutions that provide a safer environment for home buyers. Working together, we can make healthy indoor living a reality.

The  
**7 Advantages**  
of nanoe™ X  
purification technology

DEODORIZES	INHIBITS 5 TYPES OF POLLUTANTS*					MOISTURIZES
 Odors	 Bacteria & viruses	 Mold	 Allergens	 Pollen	 Hazardous substances	 Skin & hair

<sup>1</sup> Tested with gram-positive bacteria (Staphylococcus epidermidis) showing a 99% reduction following continuous operation for 24 hours in a 1,728ft<sup>3</sup> (49 m<sup>3</sup>) room. Data support a 99% reduction of the virus (Bacteriophage Ø X174) following continuous operation for 8 hours in 883ft<sup>3</sup> (25 m<sup>3</sup>) room. Data supports a reduction of mold (Alternaria) following continuous operation for 8 hours in 812ft<sup>3</sup> (23 m<sup>3</sup>) room.

<sup>2</sup> Allergens refers to non-living material.

<sup>3</sup> Refer to local jurisdictions and manufacturer installation guide.



### Current Problem:



Poor airflow resulting in callbacks

### EZ Solution:

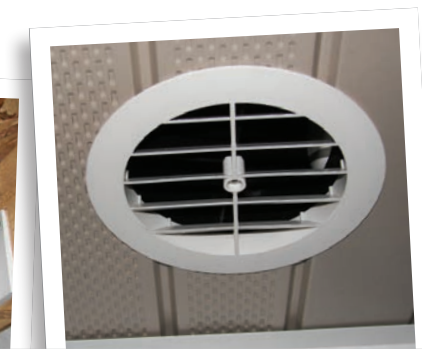

Optimized airflow means fewer callbacks

### Terminate callbacks

Save time and money with pre-soffit installation

As you know, fewer trips to the job site mean a better bottom line. Current practices and products for venting fans at the soffit can lead to poor system performance. The new EZ Soffit Vent from Panasonic is the only HVI certified termination system that lets you complete all the ducting before the soffit is installed. This helps you obtain optimal airflow, so you get fewer callbacks resulting in lower costs. It also eliminates water intrusion costs associated with roof and/or wall terminations. EZ Soffit Vent can be rotated to align with duct work and a low resistance back damper eliminates drafts and improves blower door test results.

FV-WC10VE1

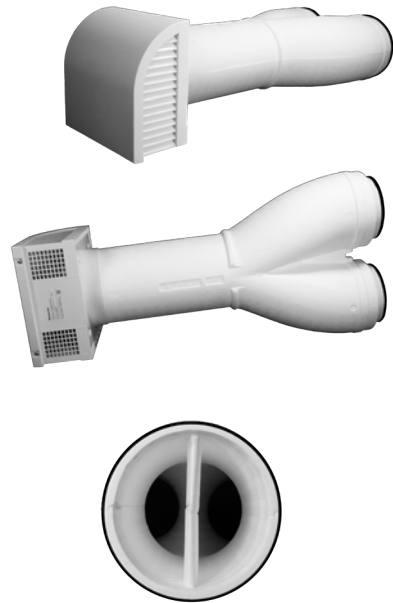

KEY FEATURES

- Designed for use with WhisperComfort® and Intelli-Balance® 100 ERV models
- Air flow rated up to 100 CFM per side
- The material composition for the duct is expanded polystyrene and polypropylene for the cap
- The duct length is 26-7/8"
- The cap height is 10-3/8" and depth of 4-15/16"
- 3-year warranty

EZSoffitVent™

EZSV14



EZ Soffit Vent installed

KEY FEATURES

- Patented soffit termination system ideal for new residential construction
- First-to-market, HVI-Certified soffit vent helps optimize airflow by letting you complete all ducting before soffit panel install
- High performance soffit vent improves overall fan performance and reduces call backs due to poor airflow
- Simple, one-stop installation helps reduce total installed costs (callbacks, labor and parts)
- Unique design eliminates water intrusion costs associated with roof and/or wall terminations
- EZ Soffit Vent body snap-fits easily into mounting bracket and can be rotated 180 degrees to align with ducting
- Low resistance backdraft damper eliminates cold drafts and improves blower door test results



1 - With any use for intake air, you must remove the damper. It's also recommended you add an insect screen (not included).



Scan here for  
EZ Soffit Vent  
installation video

Ceiling Radiation Damper

PC-RD05C5



KEY FEATURES

- One damper for both Combustible and Non-Combustible Assembly Ratings
- Damper allows for two-stage construction; fan housing and damper sleeve during framing, fan/motor/damper installation after finishes
- Damper allows access to fan/motor/damper for maintenance
- Compatible with most Panasonic 10 1/4" 50 – 150 CFM fans, fan lights and fan with motion sensor\*
- Galvanized steel frame with 165°F fusible link
- High temperature, non-asbestos, reinforced fiber thermal fabric damper

UL Approved for the Following Fan Models:*	
Damper Model PC-RD05C5	WhisperGreen Select, WhisperCeiling DC, WhisperSense DC, WhisperFit DC, WhisperValue DC



\*Please see product submittal for approved model numbers

-UL and Warnock Hersey 555C classification for 1, 2 or 3 hour Non-Combustible Assemblies

-UL 555C classification for the following 1 hour UL Wood Truss Assembly Ratings: L521, L528, L546, L558, L562, L574, L576, L581, L583, L585, M509; P522, P-533, P-538, P-545 and P-547

Optional Designer Grilles



FV-GL3TDA



FV-GL3TDB

KEY FEATURES

- Easy and affordable to change
- Change your grille to fit your room decor without compromising the performance and quality of the unit

Characteristics	FV-GL3TDA	FV-GL3TDB
Grille Size (inches sq.)	13	14-1/5
Shipping Gross Weight (lbs)	1.1	1.3
Trend Style Category	Traditional	Traditional
Material	ABS	ABS
UL Approved <sup>1</sup>	Yes	Yes
HVI Certified <sup>1</sup>	Yes	Yes
Mfg. in ISO 9001 Certified Facility	Yes	Yes

FV-WCSW21-W  
(White)



FV-WCSW31-W  
(White)



FV-WCSW41-W  
(White)



**KEY FEATURES**

- Multi-switch combination devices save space and add convenience
- Engineered to efficiently control current LED lighting and DC motor loads
- Common feed shunted internally to all switches
- Elegant decorator styling provides multiple controls in a single gang wall box
- Fits single gang box / Includes matching wall plate
- Commercial Grade
- 2-year limited warranty

Specifications	FV-WCSW21-W	FV-WCSW31-W / FV-WCSW41-W / FV-WCSW31-W
Ground	Grounding	Grounding
Feature	Single Pole / Single Pole	Single pole / double throw on-off-on switch, two single pole on-off switches
Amperage	15 Amp	Individual Switch Amperage 15 Amp Total Switch Amperage 20 Amp
Voltage	120 Volt	120 Volt
Terminations	Side Connection	Quickwire and wire leads
Standards & Certifications	UL/CSA Listed	UL/CSA Listed
Warranty	2 Year Limited	2 Year Limited



**Recessed Inlet**

FV-NLF46RES 4" or 6" Duct



**KEY FEATURES**

- Includes (1) replaceable 8W GU24 base LED lamp, JA-8 compliant for CA Title 24 and Title 20
- Multi-purpose exhaust and supply recessed inlet is ideal for use with remote mount in-line fans and ERV's
- Can be used as a light only option matching the WhisperRecessed® LED fan with a dimmable LED light
- Incorporates an architectural grade recessed can light design
- Beautiful lighting with 6" aperture and advanced luminaire design
- Insulation contact rated



**LED Lamp**

INCLUDED: (1) 8 Watt GU24 base LED lamp /2700 Kelvin Warm White />92CRI/720 lumens/90 LPW/ JA-8 compliant for CA Title 24 and Title 20, 25,000 rated average life.



FV-WCPT1-W  
Fan/Light Control, Delay Timer  
Wall plate not included



**KEY FEATURES**

- Earn ENERGY STAR® points for enhanced exhaust ventilation
- Replaces both fan and light switches for one easy operation
- Microprocessor technology provides precise ventilation times
- Programmable DELAY and VENTILATION settings
- Excess manual and/or delay operation is subtracted from the next hours programmed ventilation time
- Works with ALL incandescent, CFL, fluorescent and LED lights
- Make standard bath fans ASHRAE 62.2 compliant when used with ASHRAE 62.2 complaint fans

**Configuring Ventilation Time**

In order to properly set the VENTILATION time on your SmartExhaust™, you will need to know the code required CFM (Cubic Feet Per Minute) for your home and the Fan CFM. Follow this simple equation to calculate the VENTILATION minutes per hour.

$$\frac{\text{Code Required Ventilation in CFM}}{\text{Fan CFM}} = \text{Hour Fraction}$$

$$\text{Hour Fraction} \times 60 \text{ Minutes} = \text{Ventilation Settings in Minutes}$$

CFM = Cubic Feet Per Minute

**SmartExhaust™ Settings:**

**VENTILATION** setting allows the user to set the number of minutes per hour the fan should run.

**DELAY** setting allows the user to set the number of minutes the fan should run after the bathroom light has been turned off. This setting provides additional run time for the fan to complete the remaining necessary ventilation after use. **SmartExhaust™** replaces an existing switch, there are no additional labor costs required for installation. Simple and economical fan and light operation is provided by one switch.

**Example**

The SmartExhaust™ has a microprocessor in it that reads the two settings dials. If for example the VENTILATION dial is set to 20 minutes/hour, the microprocessor will subtract 20 minutes from 60 minutes and determines that the SmartExhaust™ needs to come on 40 minutes into the hour and run for the remaining 20 minutes of that hour.

If the DELAY dial is set to 10 minutes and the light/fan switch is manually turned on for 5 minutes, the microprocessor will keep track of the 5 minutes of use. When the switch is turned off after the 5 minutes, the microprocessor will continue to run the fan for the 10 minutes of DELAY setting adding up to a total of 15 minutes. The 15 minutes will be subtracted from the total required 20 minutes of VENTILATION time. 55 minutes into the hour, the fan will turn on and run for the 5 additional minutes needed to complete the required ventilation.

See diagram for more details

**A Normal Hour of Operation with no occupancy**

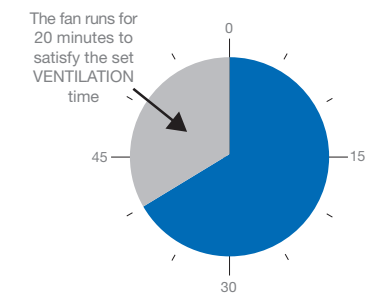

**The Bathroom is occupied for 5 minutes**

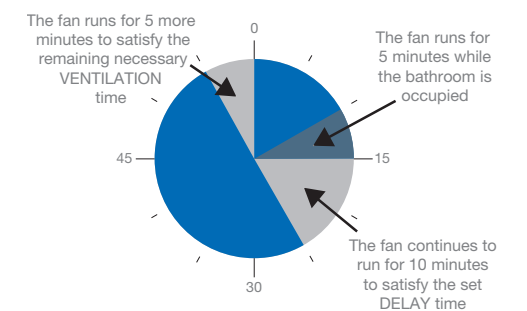

## WhisperGreen Select

### FV-0511VK3 50-80-110 FV-0511VK3 30-110

- Fan with multi-speed tested with 6" duct
- Certified Performance with 4" duct available

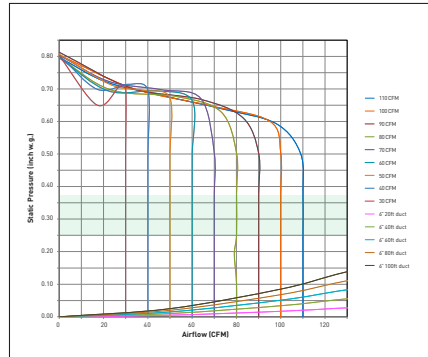

### FV-1115VK3 110-130-150 Base Fan + FV-VS15VK1 50-150 Tested with 6" duct

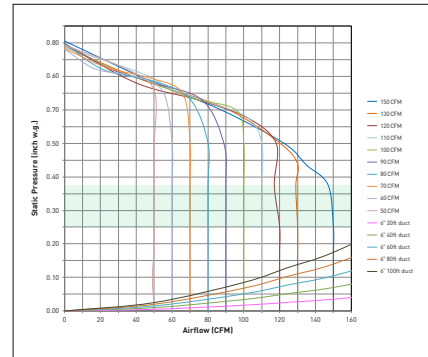

### FV-1115VKL3 110-130-150 Base Fan + FV-VS15VK1 50-150 Tested with 6" duct

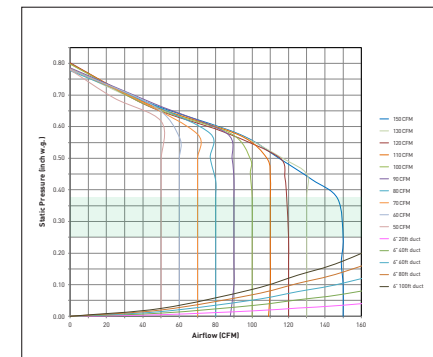

### FV-0511VKS3 30-110

- Architectural Grille Fan with multi-speed tested with 6" duct
- Certified Performance with 4" duct Available

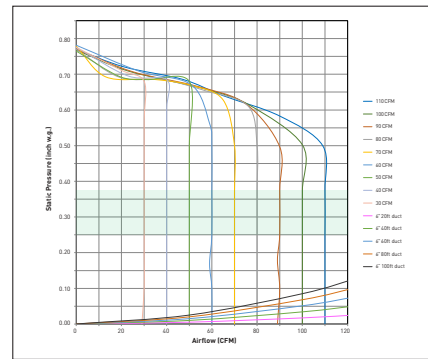

### FV-0511VKSL3K 30-110

- Architectural Grille LED Fan with multi-speed tested with 6" duct
- Certified Performance with 4" duct available

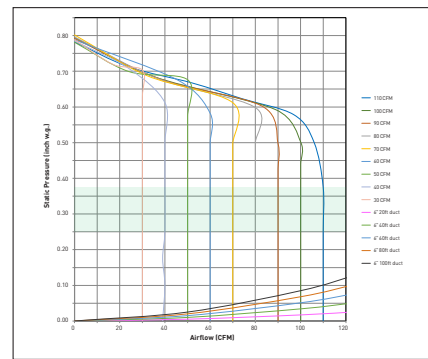

### FV-0511VKL3 50-80-110 FV-0511VKSL3 30-110

- Fan + LED with multi-speed tested with 6" Duct
- Certified Performance with 4" duct Available

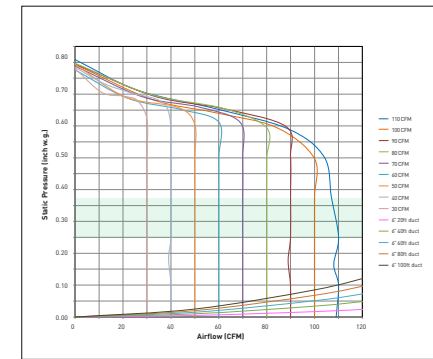

## WhisperValue DC

### FV-0510VS1 50-80-100 CFM 4" Oval Duct

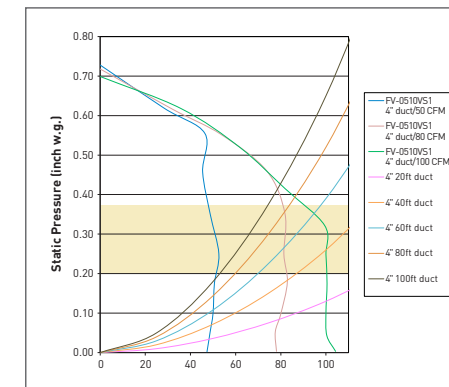

### FV-0810VSS1 80-100 CFM 4" Oval Duct

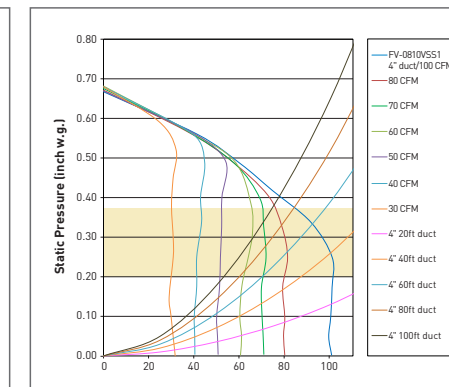

### FV-0510VSC1 50-80-100 CFM 4" Oval Duct

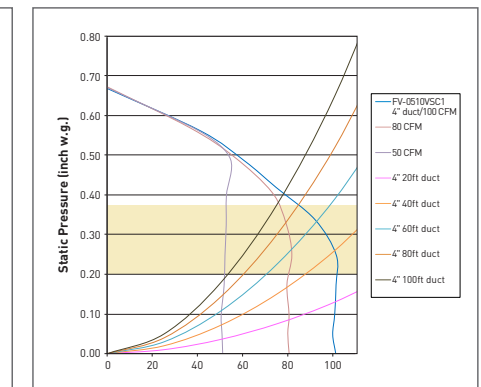

### FV-0510VSL1 50-80-100 CFM 4" Oval Duct

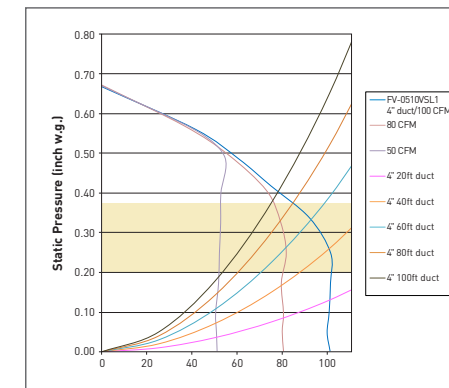

### FV-0810VSSL1 80-100 CFM 4" Oval Duct

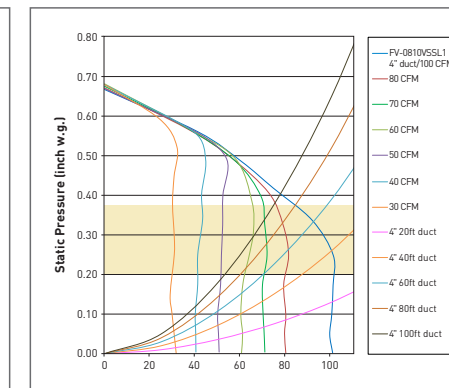

### FV-0510VSL1 50-80-100 CFM 4" Oval Duct

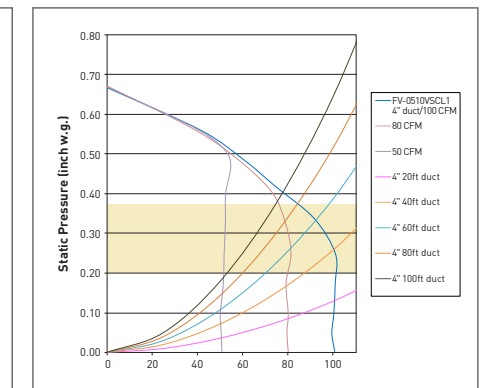

**FV-0511VF1 - 3" Duct**

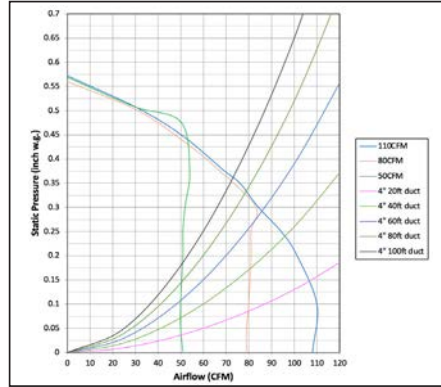

**FV-0511VFC1 - 3" Duct**

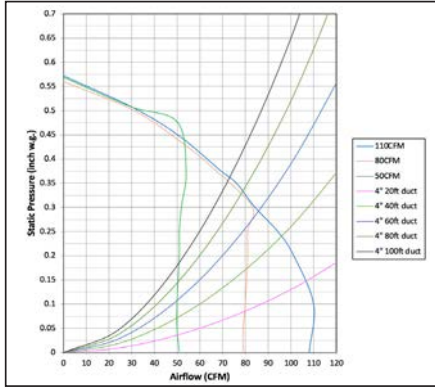

**FV-0511VFL1 - 3" Duct**

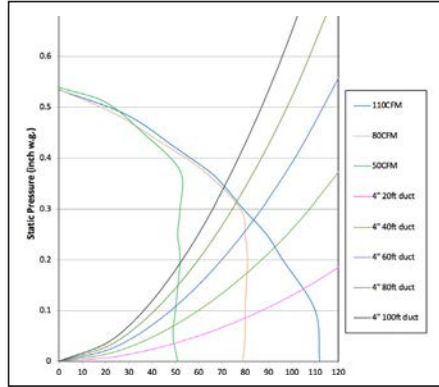

**FV-0511VF1 - 4" Duct**

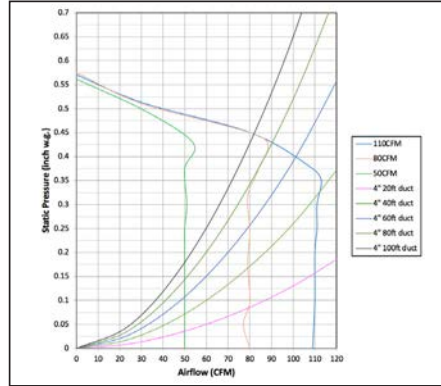

**FV-0511VFC1 - 4" Duct**

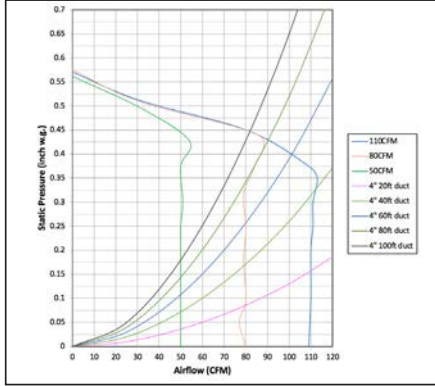

**FV-0511VFL1 - 4" Duct**

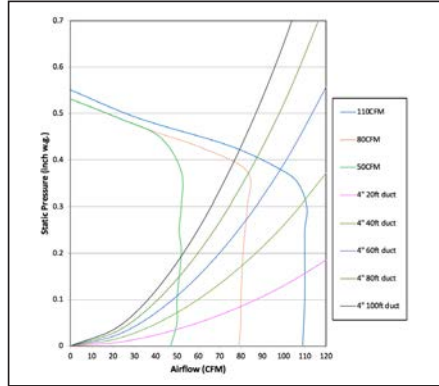

**FV-0511VQ1 50-80-110 CFM 4" or 6" Duct**

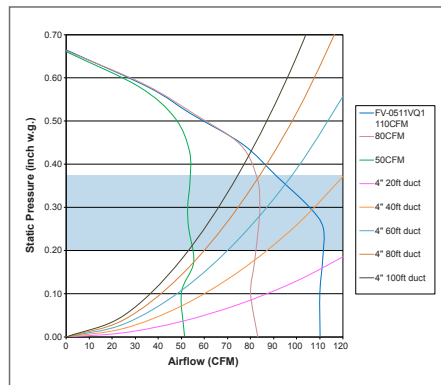

**FV-1115VQ1 110-130-150 CFM 6" Duct**

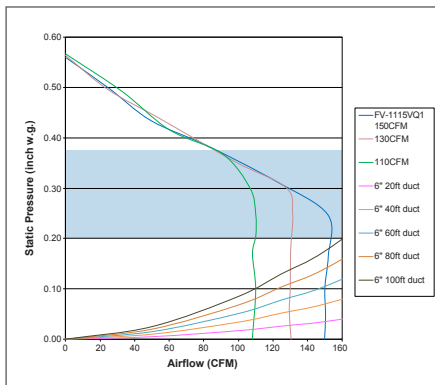

**FV-0511VQL1 50-80-110 CFM 4" or 6" Duct**

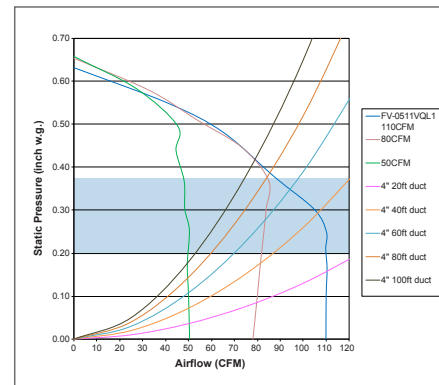

**FV-1115VQL1 110-130-150 CFM 6" Duct**

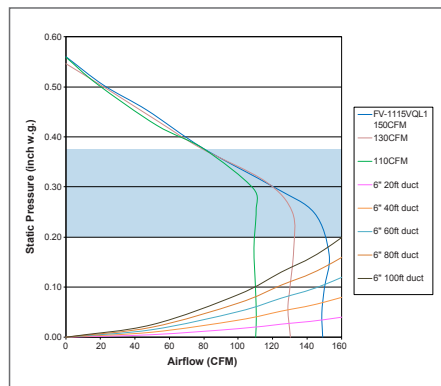

**FV-20VQ3 190 CFM 6" Duct**

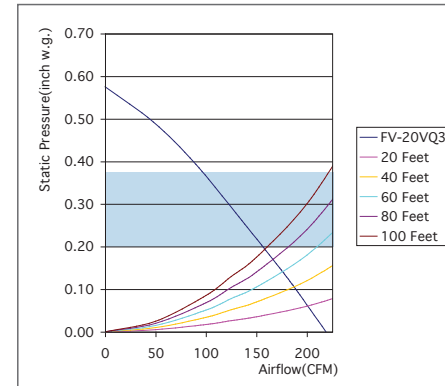

**FV-30VQ3 290 CFM 6" Duct**

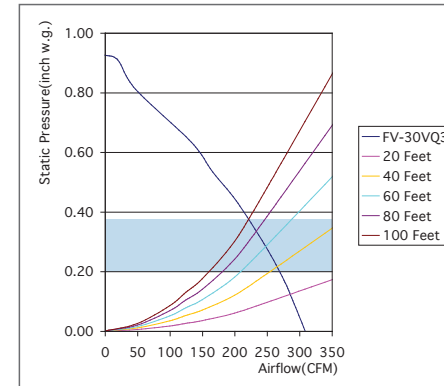

**FV-40VQ4 390 CFM 6" Duct**

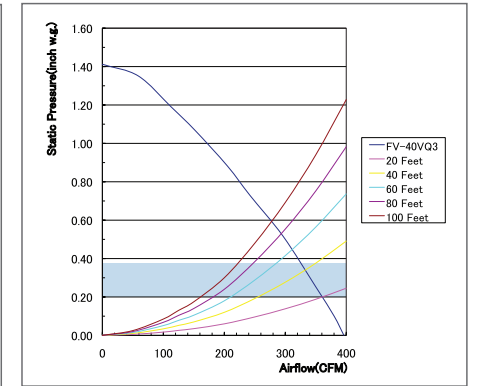

**FV-07VBA1A + FV-07VBB1 4" Ducts**

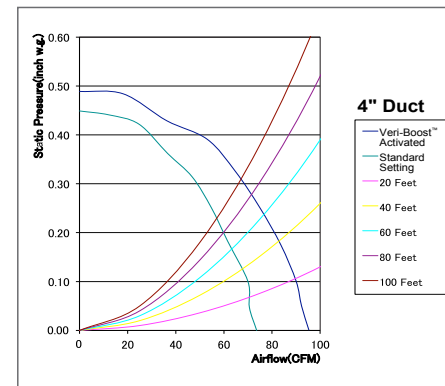

**FV-08VRE2 80 CFM 4" or 6" Duct**

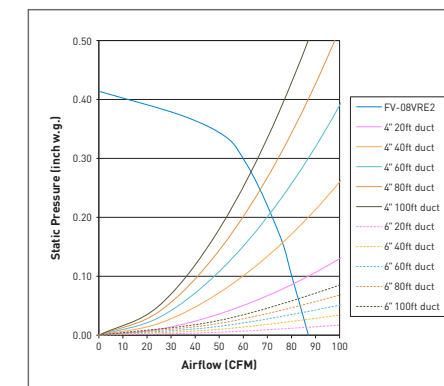

**FV-0511VQC1 50-80-110 CFM 4" or 6" Duct**

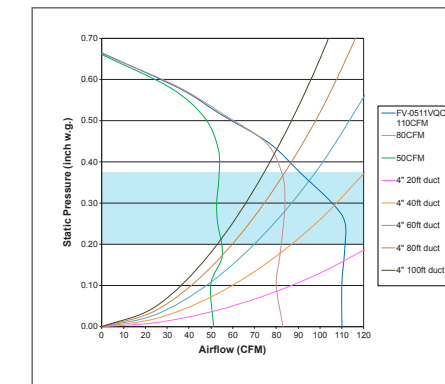

**FV-0511VQL1 50-80-110 CFM 4" or 6" Duct**

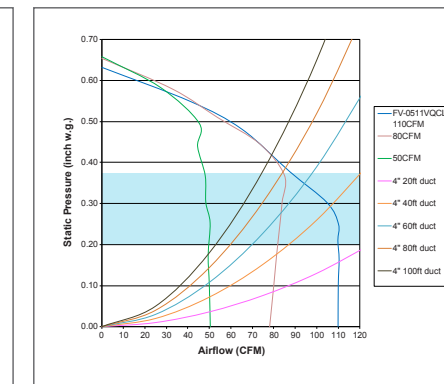

**FV-0511VH1** 110 CFM 4" Duct

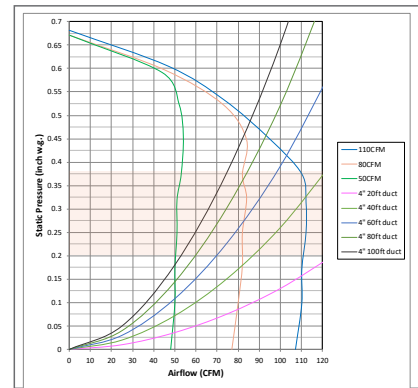

**FV-0511VHL1** 110 CFM 4" Duct

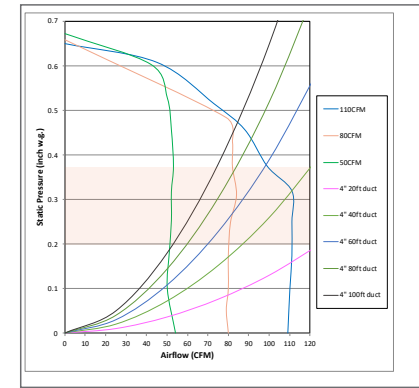

**FV-15NLF51H** 50-150 CFM 6" Duct

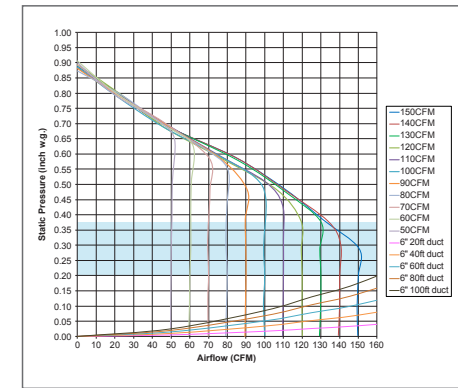

**Intelli-Balance 100 Airflow Performance Curve** 4 or 6" Ducts

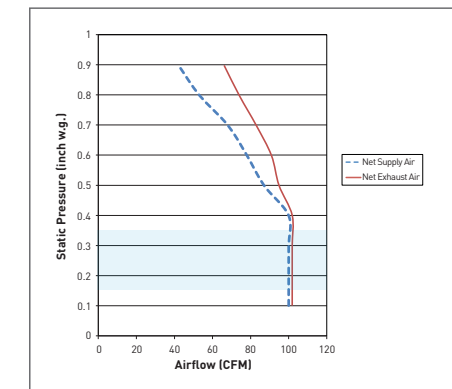

**FV-20VEC1** 200 CFM 6" Ducts

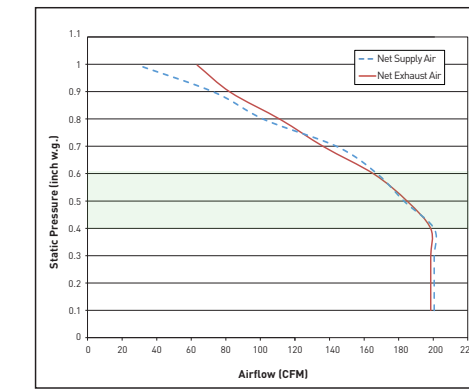

**FV-16VEC1T Net Supply**

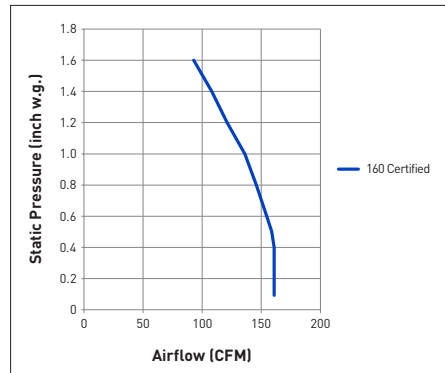

**FV-16VEC1S Net Supply**

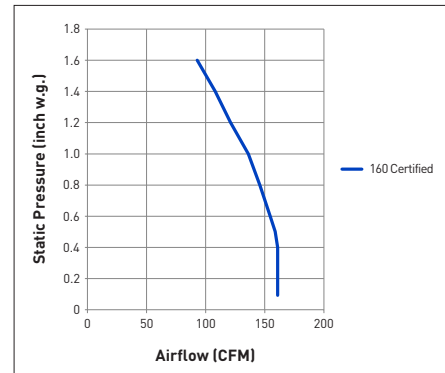

**FV-13VEC1T Net Supply**

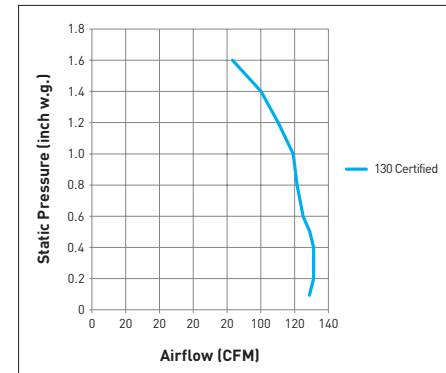

**FV-13VEC1S Net Supply**

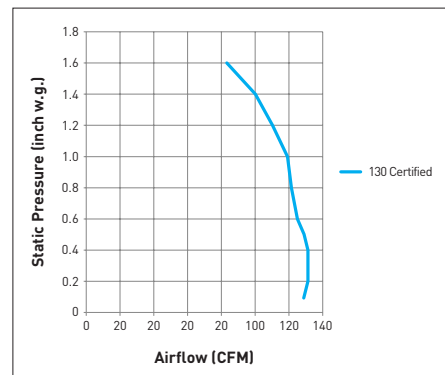

**FV-15VE1T Net Supply**

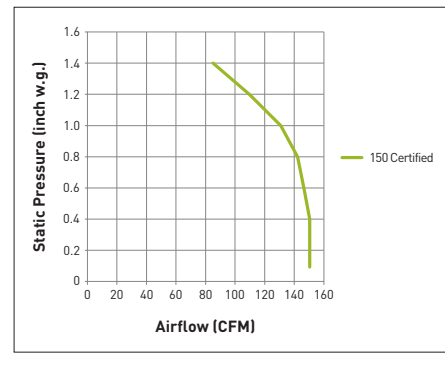

**FV-15VE1S Net Supply**

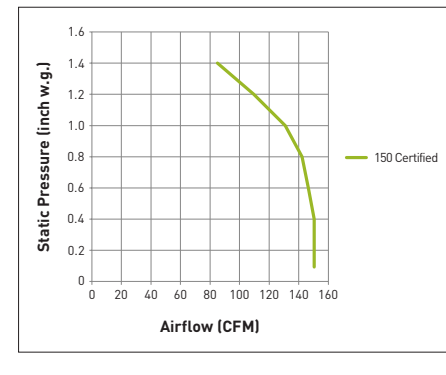

**FV-12VE1T Net Supply**

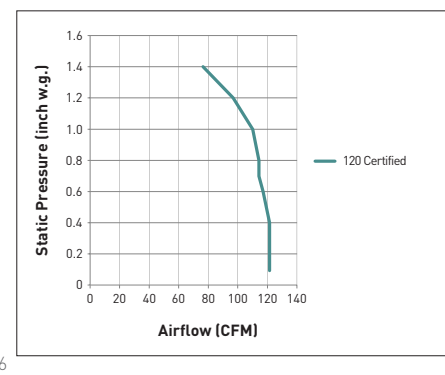

**FV-12VE1S Net Supply**

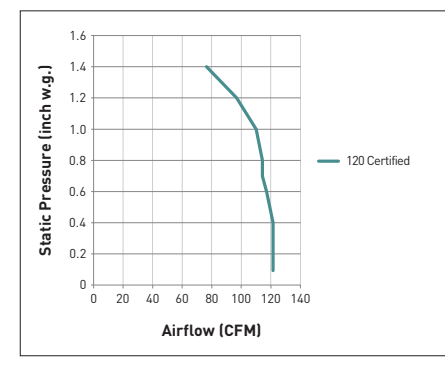

**FV-NLF46RES** 4" or 6" Duct\*

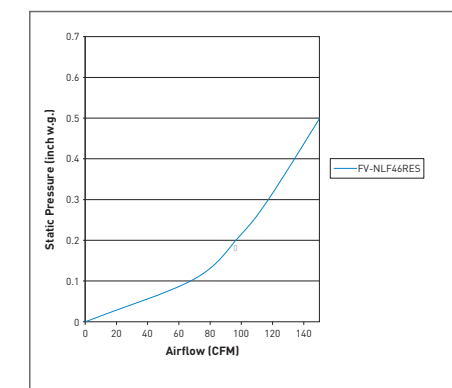

\*Data is not HVI certified as there is no testing standard.

PURIFIED BY **nanoe<sup>™</sup>X**

**FV-01VCN1**

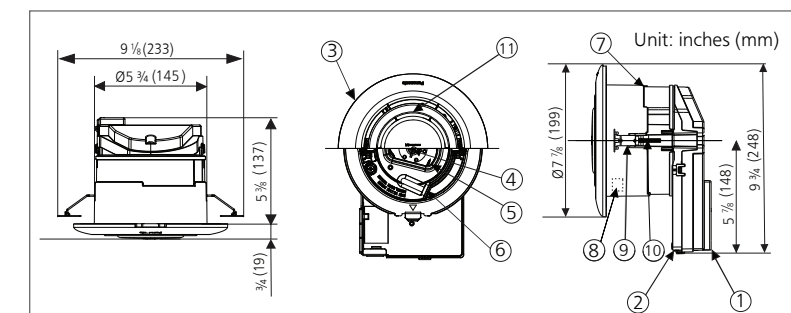

No.	Part name	Qty.	No.	Part name	Qty.
①	Junction cover	1	⑦	Frame	1
②	Electric case assy	1	⑧	nanoe <sup>™</sup> X unit	1
③	Grille	1	⑨	Install plate	2
④	Motor	1	⑩	Install screw	2
⑤	Fan	1	⑪	LED Light	1
⑥	nanoe <sup>™</sup> X cover	1			

**WhisperGreen<sup>®</sup> Select**  
VENTILATION FAN

FV-1115VK3

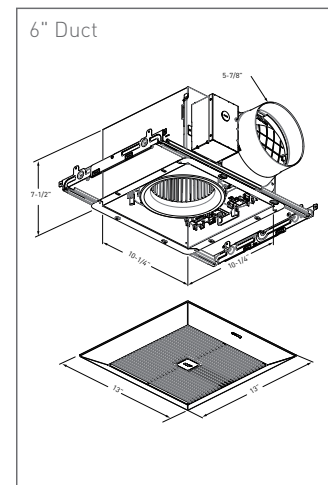

FV-1115VKL3

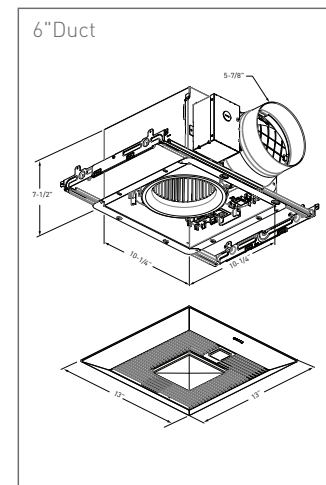

FV-0511VKSL3K

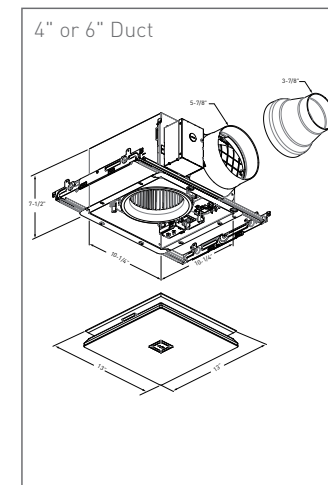

FV-0511VKS3S

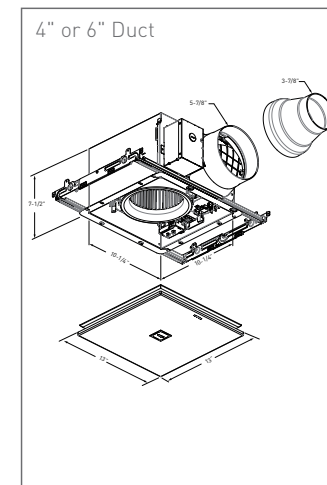

FV-0511VKS3

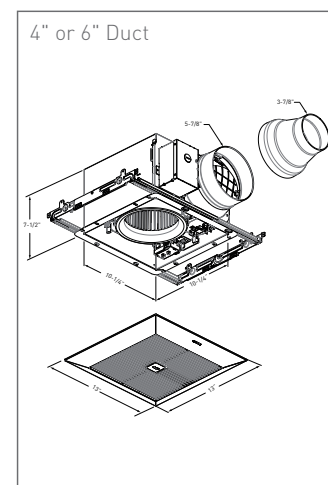

FV-0511VK3

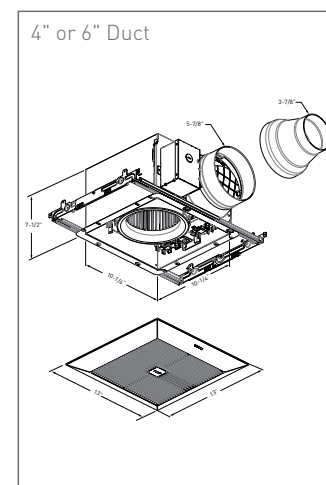

FV-0511VKSL3

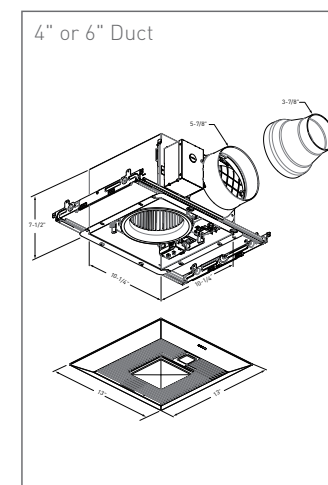

FV-0511VKL3

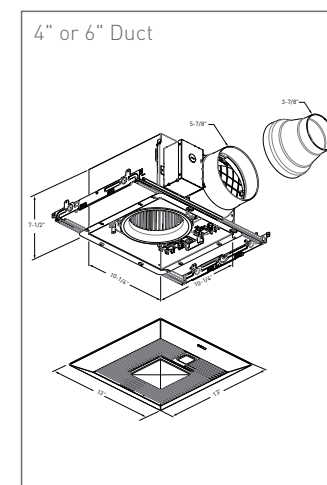

**WhisperFit<sup>®</sup> DC**  
VENTILATION FAN

FV-0511VF1

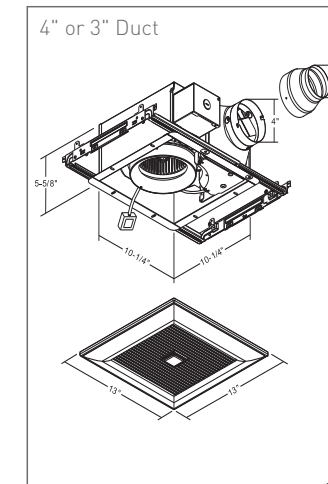

FV-0511VFC1

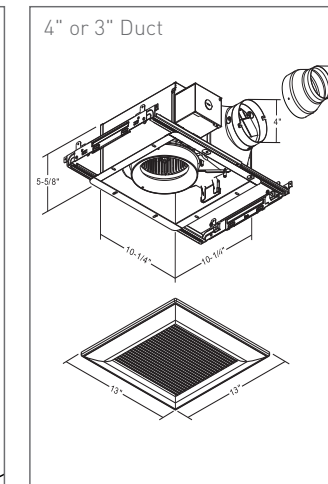

FV-0511VFL1

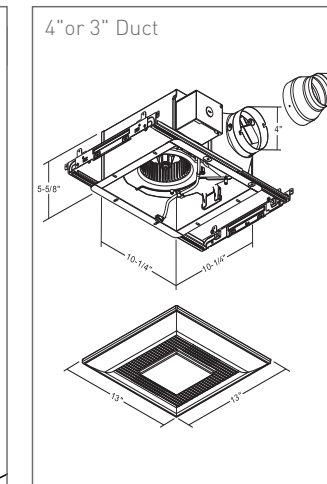

**WhisperValue<sup>®</sup> DC**  
VENTILATION FAN

FV-0510VS1

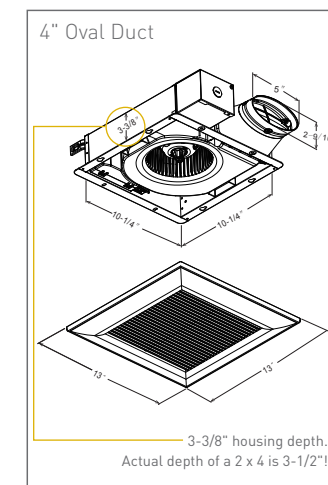

FV-0810VSS1

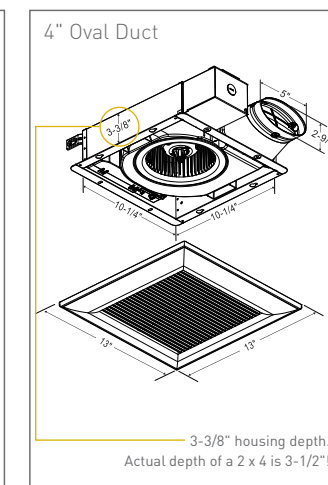

FV-0510VSC1

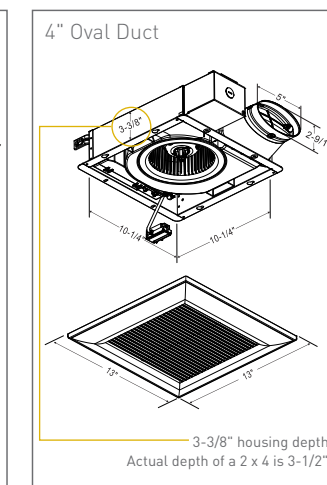

FV-0510VSL1

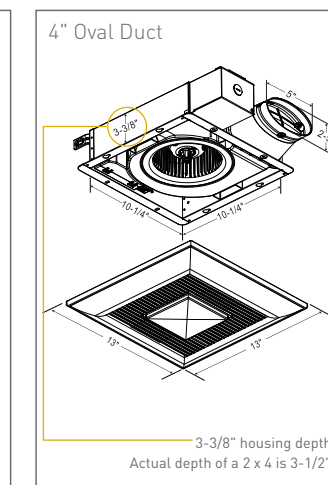

**WhisperSense<sup>®</sup> DC**  
VENTILATION FAN

FV-0511VQC1

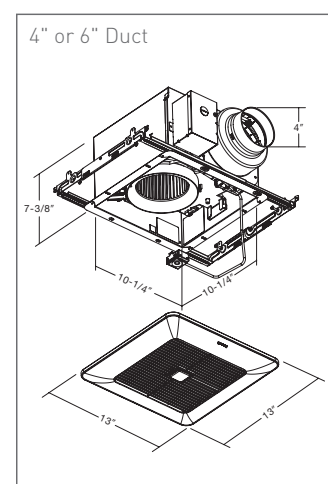

FV-0511VQCL1

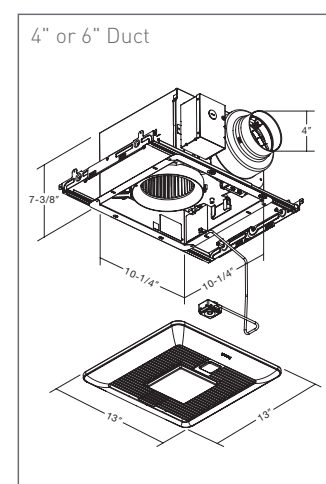

FV-0810VSSL1

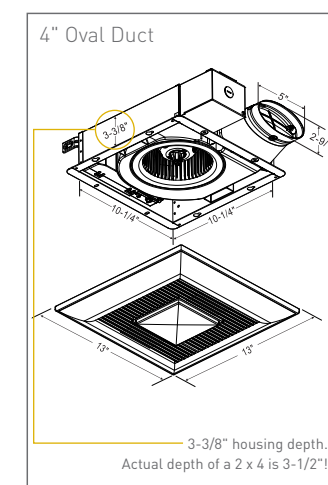

FV-0510VSC1

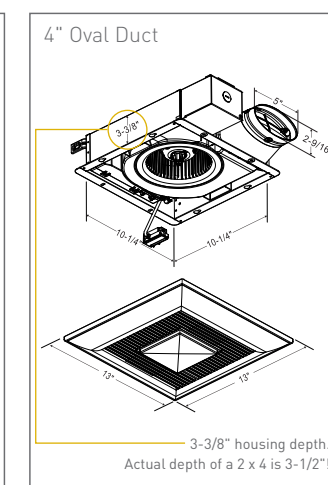

**ecovent**  
VENTILATION FAN

FV-0709VB1 / FV-07VBA1A + FV-07VBB1

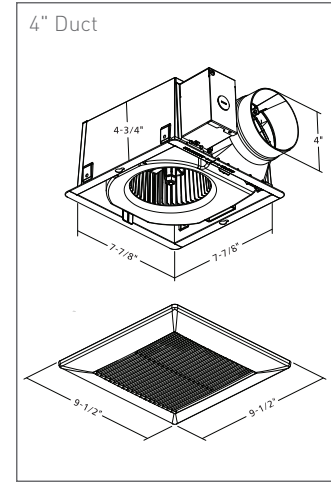

**WhisperRecessed LED**  
VENTILATION FAN

FV-08VRE2

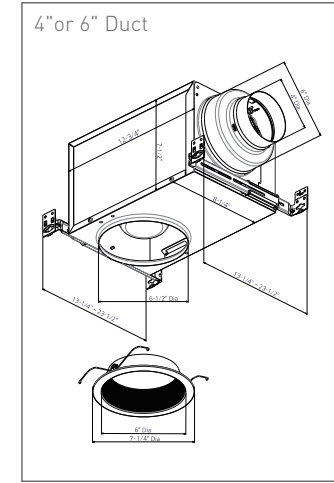

**WhisperCeiling DC**  
VENTILATION FAN

FV-0511VQ1

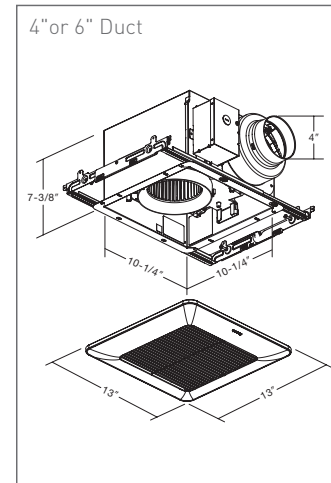

FV-1115VQ1

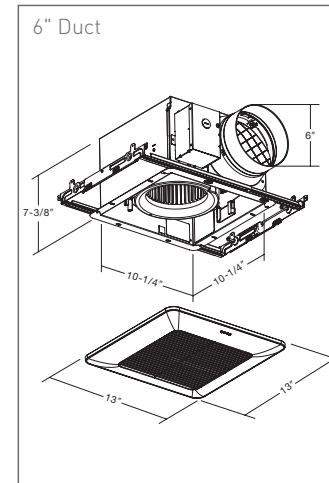

FV-0511VQL1

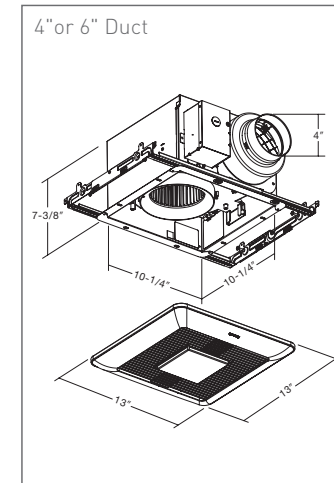

FV-1115VQL1

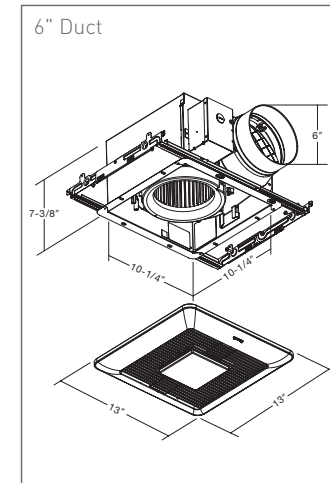

**WhisperCeiling**  
VENTILATION FAN

FV-20VQ3

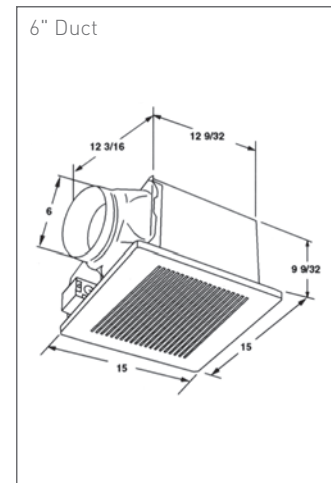

FV-30VQ3

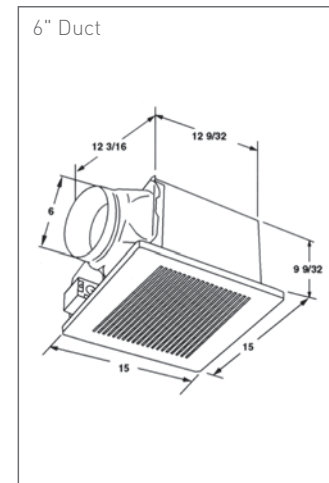

FV-40VQ4

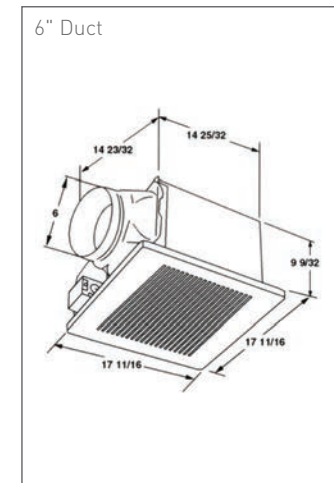

**BalancedHome**

- FV-16VEC1T FV-15VE1T
- FV-16VEC1S FV-15VE1S
- FV-13VEC1T FV-12VE1T
- FV-13VEC1S FV-12VE1S

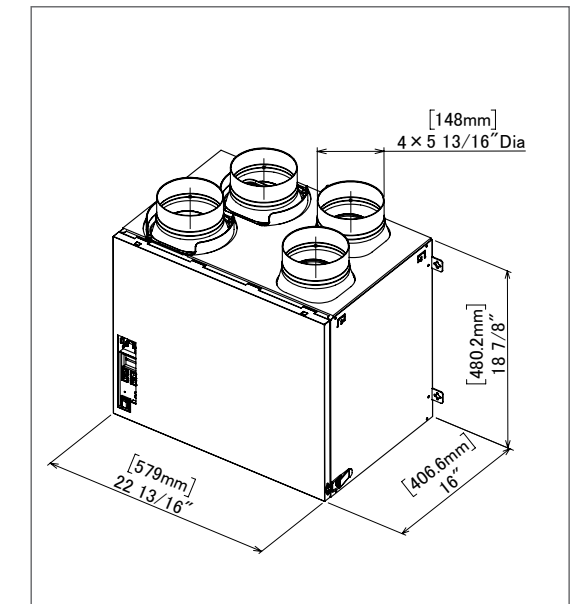
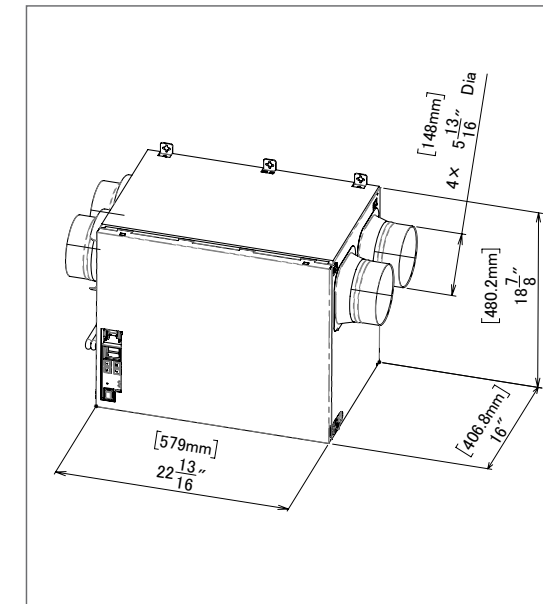

**Intelli-Balance 100**

- FV-10VEC2RH / FV-10VEC2H / FV-10VE2H
- FV-10VEC2R / FV-10VEC2 / FV-10VE2

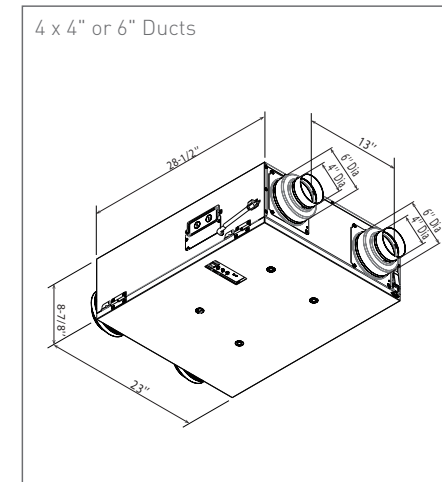

FV-10VEC2RH

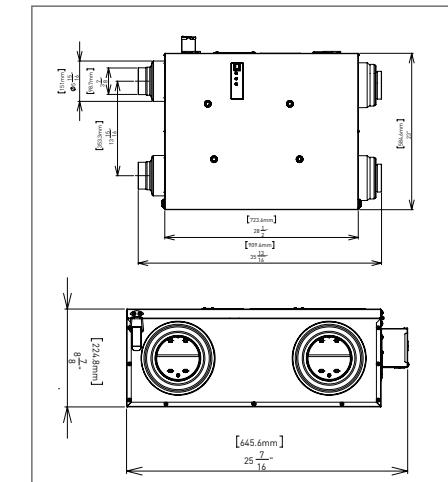

**Intelli-Balance 200**

FV-20VEC1

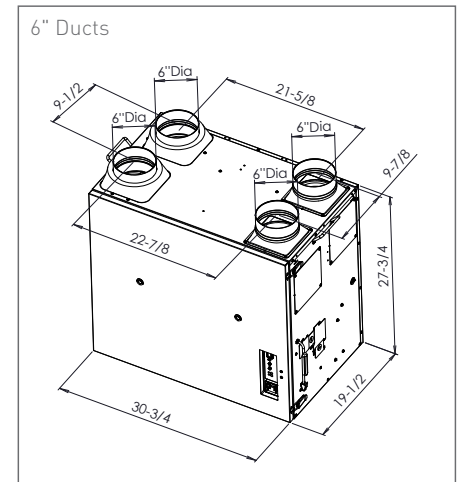

## WhisperComfort<sup>®</sup> 60

FV-06VE1

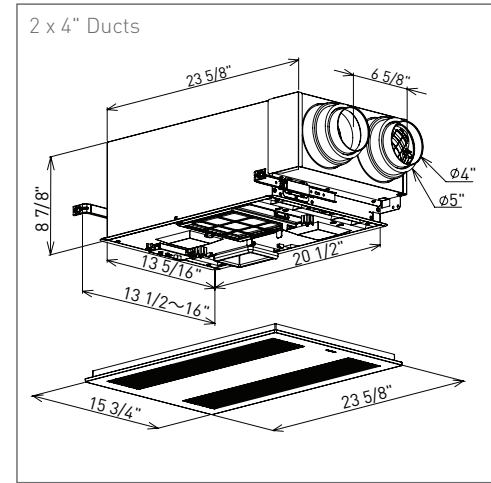

## WhisperWarm<sup>®</sup> DC

FV-0511VH1

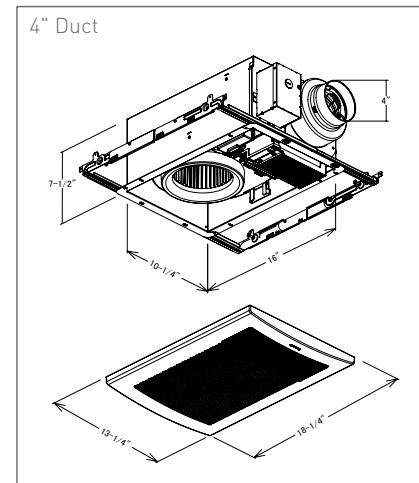

FV-0511VHL1

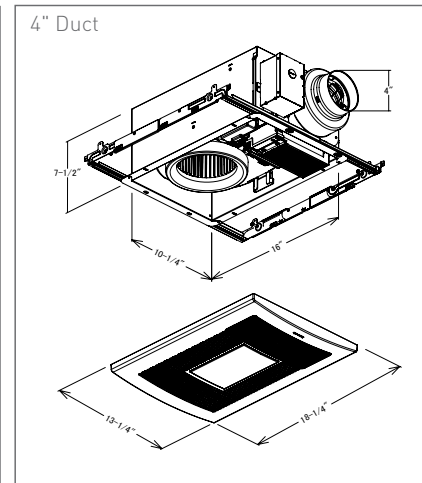

## WhisperFresh<sup>®</sup> Select

FV-15NLF51H

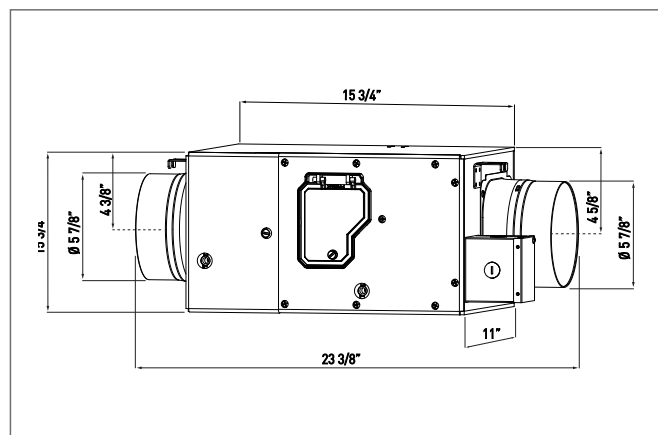

## Recessed Inlet

FV-NLF46RES

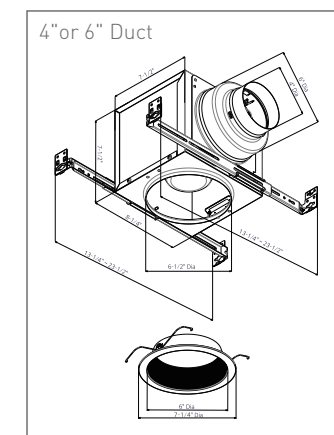

# FAQs

## Frequently Asked Questions

### 1. What is a sone?

A sone is an internationally recognized measurement of sound output. The smaller the sone, the more quiet it is. Likewise, the higher the sone, the louder the sound.

### 2. What is CFM?

CFM or Cubic Feet per Minute is a measurement of rate of air flow. The larger the CFM, the more powerful the fan.

### 3. What is static pressure?

Static pressure is a measure of the resistance against flow as the fan pushes air through a duct. Static pressure is measured in inches of water column or water gauge (w.g). It is expressed as 0.1" w.g. or 0.25" w.g. to show that the resistance is equal to a column of water one-tenth or one-quarter of an inch tall. Most bath fans sold in North America are rated and certified at 0.1" w.g. by the Home Ventilating Institute (HVI).

### 4. Why are Panasonic fans so quiet?

Fan noise comes from the amount of the blower wheel blade tip speed – the tip speed is in proportion to the revolutions per minute (RPM) of the wheel or fan blade. A small wheel turning very fast will create more noise than a large wheel turning more slowly for a given airflow. Panasonic fans use a compact blower wheel with aero dynamic

blades that moves a large amount of air at reduced RPMs. The Panasonic blower wheel is designed more efficiently than most competitor models, so it turns at lower RPMs, reducing tip speed and noise.

### Quiet Motor

Panasonic is the first ventilation fan manufacturer to incorporate a DC motor in residential mechanical ventilation fans. The WhisperGreen Select series features a removable, permanently lubricated, plug-in DC motor. The totally enclosed DC brushless motor technology is rated for continuous run and are designed for extremely quiet, energy efficient operation. Panasonic DC motors consume 30% less energy than AC motors and each one comes equipped with a thermal cutoff fuse for added protection and safety.

All other Panasonic fan series incorporate a totally enclosed four-pole condenser AC motor, which is an advanced version of a Permanent Split Capacitor (PSC) motor. These are among the most energy efficient fan motors made.

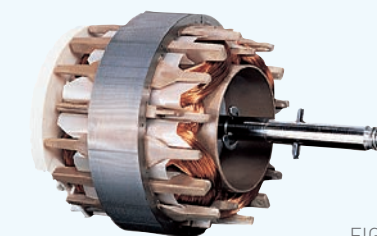

FIG. 1

### 5. What makes Panasonic fans so highly energy efficient?

The input wattage readings on the Panasonic fans are among the lowest in the industry. This means that for a given airflow, Panasonic fans will use fewer kilowatt hours and cost less to operate than other fans. This lower wattage draw is accomplished in a number of ways:

### Unique Motor Design

Panasonic's DC brushless motor provides unparalleled energy efficiency with its magnetic rotor and printed circuit board. The magnetic rotor prevents energy loss while standard AC motors that utilize aluminum die cast rotors expend energy. Also, Panasonic's DC motor is the only one to incorporate a print circuit board containing a unique IC chip which monitors and directs the RPM of the fan blade. The combination of these two unique features allows the DC motor to have higher energy efficiency than an AC motor.

Panasonic uses a four-pole condenser motor, which is composed on a main coil and a sub coil. The coils in a motor are essentially small electromagnets that are turned on and off to create an electrical field to "pull" the fan shaft around, making the fan blower wheel turn. The condenser is connected with the sub coil, which helps with

rotation. The condenser acts like a capacitor to store electrical energy and deliver it quickly and in exact amounts to the coil. This improves the electrical efficiency of the motor and reduces power draw.

### **Selective Application**

Panasonic builds its own motors and components, which means tight control over quality. Panasonic engineers also optimize efficiency by matching the exact motor characteristics with the desired performance of the fans.

### **6. Why do Panasonic fans have such a long life?**

Panasonic fans are designed to give the consumer trouble-free continuous operation for many years. These fans utilize high quality components and permanently lubricated motors. This leads to fans that provide a long operational life because their components wear very slowly. That is why Panasonic stands behind its products with one of the longest warranty periods in the industry.

### **Motor Production**

Panasonic motor production is fully automated, with an automatic defect detecting system. The quality assurance program is exemplary, leading to a defect rate of less than 0.0006%.

### **ISO 9001 and ISO 14001 plant**

The production facilities that build Panasonic fans have earned the distinction of being recognized by the International Standards Organization (ISO) under the ISO 9001 and 14001 Quality Assurance program. Meeting ISO 9001 and 14001 means that these factories have met the highest quality standards in the world.

### **Fan Housing**

The fan housing is made of heavy-gauge zinc-galvanized steel and painted to protect it from rust. Built-in metal flange provides blocking for penetrations through drywall as an air barrier, and assists with the decrease in leakage in the building envelope during blower door testing.

### **7. Can insulation material be used over fans installed in the ceiling?**

YES. Loose fill or batt insulation can be placed directly over the fan housing in the attic. Panasonic fans and fan/light combination units do not create excessive heat that is a common problem with recessed light fixtures or some competitors' fan/light combinations. Our efficient, cool-running motors and our fluorescent bulbs do not create enough ambient heat to be subject to these limitations.

### **8. Can a Panasonic fan be used over a bathtub and in showers?**

YES. All Panasonic fans, with the exception of heater and Spot ERV models, are listed by Underwriters Laboratories for installation over tubs and showers, provided they are protected by a Ground Fault Circuit Interrupter (GFCI). GFCI is mandated by the National Electrical Code. While not specifically listed by UL as an application, the fan can also be installed in a steam shower enclosure. Keep in mind, however, that any ventilation device located in a damp environment such as a shower enclosure may have a reduced life due to the high humidity and potential for corrosion. Fans installed in a high humidity environment should be operated for longer periods of time to ensure the removal of the moisture and to reduce the potential for condensation in the fan body or ducting.

### **9. Can a Panasonic fan be used above a kitchen range?**

No. Panasonic fans are not currently rated by UL for above-range installation since it was not designed to handle both grease and high temperature. However, Panasonic fans can be used to provide auxiliary kitchen ventilation. An approach that works well in large kitchens is to use a ducted range hood or downdraft exhaust and

a Panasonic ventilation fan to exhaust the general odors and moisture in the greater kitchen area.

### **10. Why are Panasonic fans not required to be IC rated?**

Fans are not required by UL to be IC (Insulation Contact) rated because they do not have high temperature sources like recessed can lights. The Panasonic fan/light combo units use fluorescent lamps that are mounted in a light kit that is considered to be surface mounted, so they do not create high temperatures within the fan housing that would require an IC rating.

### **11. What's better, a motion sensor or a humidity sensor?**

While the humidity sensor checks the amount of moisture at the ceiling, a motion sensor "sees" the occupant coming into the room. The humidity sensor has to be set to either Rate of Rise or Relative Humidity. Depending on how the fan is set up, it may or may not turn on in certain conditions. For instance, if set for Rate of Rise (how quickly moisture builds up in a room), it might not turn on when there is a steady build-up of humidity over time. On the other hand, a motion sensor will go on once it senses motion to capture moisture, odors, and contaminants from the cleaners and chemicals that may be kept underneath the sink. Panasonic's WhisperSense fans include motion and humidity

sensors for ultimate moisture control.

"Panasonic's Condensation Sensor Plus or Swidget Smart Controls with moisture management inserts are more precise ways to control a fan and avoid condensation as they measure relative humidity and air temperature."

### **12. How do I know whether my ventilation strategy meets my local codes or standards?**

While codes and standards are well documented, their adoption is unique to the region and jurisdiction. Therefore, we recommend sending us a message at [VentFans-CodesandStandards@us.panasonic.com](mailto:VentFans-CodesandStandards@us.panasonic.com), and one of our regional specialists can outline the ventilation requirements for your project based on your area.



# Ventilation Controls

Selecting a suitable control that runs ventilation at the proper time and duration will protect the occupant's health and building structure. Fan controls can also be used in combination with each other to provide both intermittent and continuous ventilation. For example, WhisperGreen Select fans with Panasonic patented Plug 'N Play modules are designed for double duty, providing intermittent and continuous ventilation. The key to selecting the proper control or combination of controls is first understanding the occupant's lifestyle and ventilation needs. Then choose a control that provides proper ventilation with little or no involvement by the occupant.

**Manual controls:** Manual controls require the occupant to activate the ventilation fan when needed. The Panasonic FV-WCSW21 On/Off rocker switch for light and fan control is an example of primary manual control. However, other controls may be more suitable to the occupant's lifestyle. For example, our (S16008WA) 20 – 40 – 60 minute timer wall control allows the occupant to either turn the fan off directly or run for a determined time and turn itself off automatically.

**Electronic timers:** Electronic timers are more decorative and allow the occupant to select a time duration with the push of a button. Electronic timers do not produce the annoying ticking sound that crank timers are known for. WhisperGreen Select and WhisperSense fans incorporate quiet electronic controls. Other controls may be more suitable to the occupant's lifestyle. For example, our (S16008WA) 20 – 40 – 60 minute timer wall control allows the occupant to either turn the fan off directly or run for a determined time and turn itself off automatically.

**Occupancy (motion) sensors:** Occupancy sensors are suitable for intermittent ventilation. An advantage is that the ventilation system will operate without relying on the occupant's interaction. Instead, the ventilation system will remain "on" and continue working after the occupant has left the room, much like a delay-off timer. WhisperGreen Select

fans can be customized to include an occupancy feature with the SmartAction® Motion Sensor Plug 'N Play® module. The WhisperSense family of fans has an occupancy sensor integrated into the fan grille.

**Humidity and moisture sensors:** Humidistats and Condensation Sensors turn a ventilation system on/off when relative humidity reaches a certain level. However, humidistat controls can have a few disadvantages. One disadvantage is that seasonal changes in outdoor relative humidity necessitate seasonal readjustments to function optimally. As well, humidity controls do not automatically sense and remove odors.

The Panasonic FV-WCCS1 Condensation Sensor Plus features intelligent and advanced sensor technology that monitors humidity and temperature to anticipate dew point, automatically operating the fan to control moisture. Its built-in automatic seasonal adaptability with an optional Moisture Sensitivity Selector also allows fine-tuning for dry or moist environments. Panasonic offers several fan families that can accommodate motion and humidity sensors for ultimate moisture control.

**Smart Controls:** Smart Controls combines the functionality of manual and automatic controls while incorporating pre-programmed customized rules to match customer needs.

Swidget Smart Devices and interchangeable Swidget Wi-Fi-enabled inserts empower homes to live smartly. In addition to incorporating power management options, they are the only devices in the industry to offer insertable IAQ sensors to effectively and efficiently manage air quality in a home. Swidget controls can provide a complete whole-house IAQ and energy management solution with devices and sensors distributed throughout a home.

The system's flexibility is completed using the Swidget App to remotely monitor each device, with an optional connection to Alexa or Google Assistant for voice control.

# Sizing Information and Instructions

**Equivalent Duct Length (EDL):** The Equivalent Duct Length Table (Figure B) shows you how to calculate the equivalent straight duct length in order to overcome static pressure. The EDL chart helps ensure fan performs as expected under the airflow resistance caused by the listed components.

A ventilating fan's performance is plotted on a graph called a performance curve. The performance curve shows airflow in cubic feet per minute (CFM) along the horizontal axis and static pressure (resistance) along the vertical axis.

Figure A shows how a performance curve works. The fan with a "Closed Duct" has high static pressure and no airflow; and the fan with "No Duct" has low static pressure and high airflow. In reality, an installed fan will be somewhere in between these two points.

## Sizing and selecting a Ceiling Mounted Fan:

Proper sizing requires that you determine the needed CFM, the square footage of the room or home, and the length and type of duct.

Example: Sizing for an 8 ft x 10 ft x 8 ft ceiling bathroom using 12 foot long, 4 inch diameter aluminum flex duct, one elbow, one wall cap.

**Step 1:** Determine application

**Bathroom = 1 CFM/square foot**

**Step 2:** Calculate the area to be ventilated in square feet.

Assuming an 8 ft ceiling: room length x width = area in square feet

**8 ft x 10 ft = 80 sq.ft.**

**Step 3:** Calculate your required CFM

**1 CFM x 80 sq.ft. = 80 CFM**

**Step 4:** Use the Equivalent Duct Length chart above to calculate duct run.

4a. 12 ft aluminum flex duct x 1.25 = 15 ft

4b. One elbow = 15 ft EDL

4c. One wall cap = 30 ft EDL

**15 ft + 15 ft + 30 ft = 60 ft EDL**

This is the equivalent duct length (or resistance) the fan must overcome to move air through the duct to the outside.

**Step 5:** Review models in catalog pages to find a model with desired feature. Features may include light fixture, heater or low-profile housing.

**Note:** Check with your local building inspector to confirm that these methods are accepted in your area.

**Step 6:** Use the EDL calculated in Step 4 to check on the performance curve for the fan selected in Step 5. Compare your calculated EDL to the curves for different EDLs on the performance curve for your selected product. Where they cross will tell you what airflow to expect. For the 60 feet of EDL in the example, interpolate between the curve for 50 feet and the one for 75 feet.

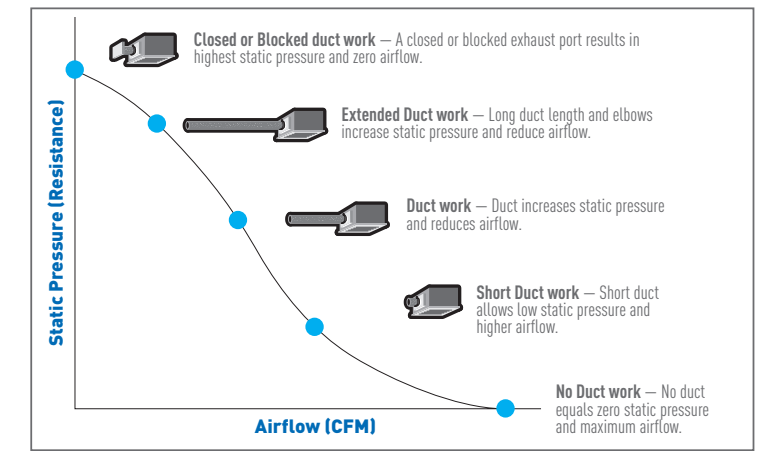

FIG. A

Equivalent Duct Length					
Duct Diameter					
		3"	4"	6"	8"
Duct	Smooth Metal	Same as measured duct length			
Material	Flex Aluminum	1.25 x duct length	1.25 x duct length	1.5 x duct length	1.5 x duct length
	Insulated Flex	1.5 x duct length	1.5 x duct length	1.75 x duct length	1.75 x duct length
Terminal	Wall Cap	30 feet	30 feet	40 feet	40 feet
Device	Roof Jack	30 feet	30 feet	40 feet	40 feet
Elbow	Adjustable	15 feet	15 feet	20 feet	20 feet

FIG. B



# Installation

## A practical guide to Panasonic fan installation

Proper fan installation is necessary to optimize performance. The following points outline installation techniques to help achieve optimum performance.

**IMPORTANT:** In order to reduce elbows and optimize fan performance, install the fan with the exhaust port pointed in the direction of the termination point. Be sure to use the duct diameter size specified for the selected fan. Reducing the duct diameter (at any point in the duct run) will create substantial static pressure and reduce the fan's performance by as much as 90%. Increasing the duct size almost always improves both sound and airflow performance.

**Selecting Duct:** A smooth surface duct allows for optimum airflow. See Figure C. For best results, use galvanized sheet metal or possibly PVC. Flexible aluminum duct is durable, easy to install and often used. However, the ridges in aluminum flexible duct increase static pressure and can reduce airflow and fan performance. This results in lower CFMs, higher noise levels and higher energy consumption. The degree to which performance is affected depends on the length of duct, number and degree of elbows.

Sagging or weaving a fan duct will also increase static pressure and reduce a fan's performance. When using a flexible aluminum duct, support the entire length of the duct with braces or hangers to keep it as straight as possible for the entire run. If the duct lies across the attic, do not allow it to sag between each joist. Also, avoid weaving duct through trusses.

Using dryer duct connectors made of nylon or vinyl is not recommended due to high static pressure caused by its ridges and curvature. Insulated flexible duct must be fully extended to avoid added resistance.

**Elbows:** Rule number one is to avoid elbows and bends whenever possible. However, the fact is that many installations require at least one elbow, as shown in Figure D. There are two precautions you can take when installing elbows to achieve optimum airflow.

First, allow a 2-3 foot straight run out of the fan before the first elbow. This allows airflow to be uniform before passing through the first elbow. An installation that has a 90-degree elbow immediately after the fan exhaust port will cause air to flow back into the fan. This will reduce fan performance and increase noise. (Figure D)

FIG. D

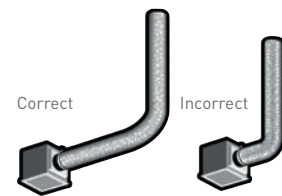

Second, use a long radius angle, as shown in Figure E, to help ensure optimum airflow and minimum airflow noise.

FIG. E

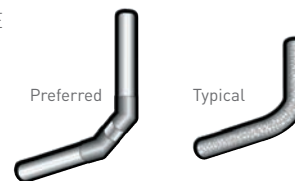

**The shortest, smooth inner surface duct with the least number of elbows will provide optimum fan airflow**

FIG. C



\*A straight run over joists is better than the duct 'dipping' into each joist bay which will increase static pressure and, eventually, deposit water in the 'dips'.

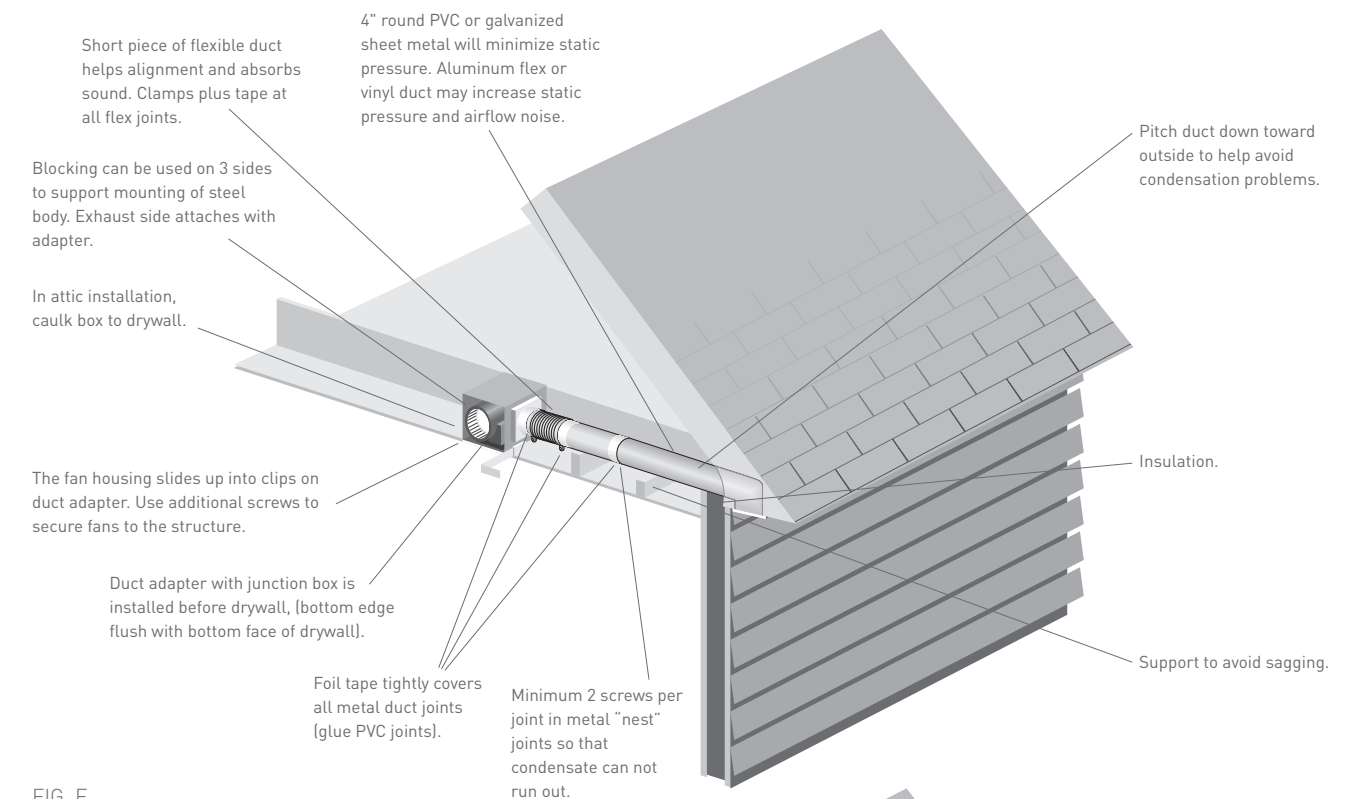

FIG. F

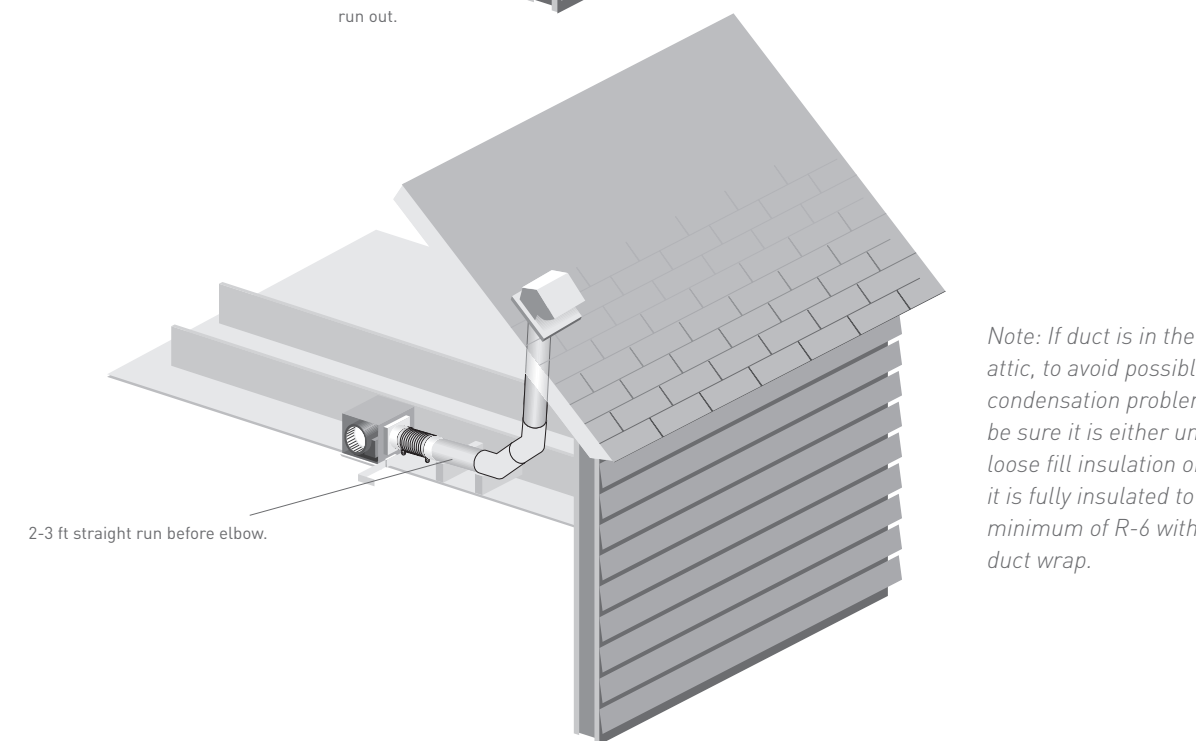

FIG. G

### Troubleshooting Advice:

1. During fan installation, the tape on the duct connector holding the damper shut must be removed.
2. Confirm with your contractor if screws were used to attach the duct to the fan. The damper may not open if obstructed by screws.
3. Check that the backdraft dampers on wall caps and roof jacks are able to move freely. Routine inspections are recommended as birds and other pests may inhabit these areas.
4. Ductwork must be connected securely to wall caps and roof jacks.



**Panasonic  
IAQ Division**

Two Riverfront Plaza  
Newark, NJ 07102

For additional information, visit:  
**[iaq.na.panasonic.com](http://iaq.na.panasonic.com)**

**Panasonic Customer Service**

9 am – 6 pm (EST) Monday through Friday  
Phone: (866) 292-7299  
Fax: (888) 553-0723

**[ventfans@us.panasonic.com](mailto:ventfans@us.panasonic.com)**

*Design and specifications subject to change without notice.*

IAQ25020CAT  
April 2025

**Panasonic**